

MH255 Hall-effect sensor is a temperature stable, stress-resistant, Low Tolerance of Sensitivity micro-power switch. Superior high-temperature performance is made possible through a dynamic offset cancellation that utilizes chopper-stabilization. This method reduces the offset voltage normally caused by device over molding, temperature dependencies, and thermal stress.

MH255 is special made for low operation voltage, 1.7V, to active the chip which includes the following on a single silicon chip: voltage regulator, Hall voltage generator, small-signal amplifier, chopper stabilization, Schmitt trigger, CMOS output driver. Advanced CMOS wafer fabrication processing is used to take advantage of low-voltage requirements, component matching, very low input-offset errors, and small component geometries. This device requires the presence of omni-polar magnetic fields for operation.

The package type is in a Halogen Free version has been verified by third party Lab.

### ***Features and Benefits***

- CMOS Hall IC Technology
- Strong RF noise protection
- 1.7 to 5.5V for battery-powered applications
- Omni polar, output switches with absolute value of North or South pole from magnet
- Operation down to 1.7V, Micro power consumption
- High Sensitivity for reed switch replacement applications
- Multi Small Size option
- Low sensitivity drift in crossing of Temp. range
- Ultra Low power consumption at 5uA (Avg)
- High ESD Protection, HBM>±4KV( min )
- Totem-pole output
- RoHS compliant 2011/65/EU and Halogen Free.

### ***Applications***

- Solid state switch
- Handheld Wireless Handset Awake Switch ( Flip Cell/PHS Phone/Note Book/Flip Video Set)
- Lid close sensor for battery powered devices
- Magnet proximity sensor for reed switch replacement in low duty cycle applications
- Water Meter
- Floating Meter
- PDVD
- NB

**Ordering Information**

	<p><b>Company Name and Product Category</b>          MH:MST Hall Effect/MP:MST Power IC</p> <p><b>Part number</b>          181,D182,183,184,185,248,477,D381,D381F,381R,D382.....          If part # is just 3 digits, the fourth digit will be omitted.</p> <p><b>Temperature range</b>          E: 85 °C, I: 105 °C, K: 125 °C, L: 150 °C</p> <p><b>Package type</b>          UA:TO-92S,VK:TO-92S(4pin),VF:TO-92S(5pin),SO:SOT-23,          SQ:QFN-3,ST:TSOT-23,SN:SOT-553,SF:SOT-89(5pin),          SS:TSOT-26,SD:DFN-6</p> <p><b>Sorting</b>  <math>\alpha</math>, <math>\beta</math>, Blank.....</p>
<p>Company Name and Product Category</p> <p>Part number</p> <p>Temperature Code</p> <p>Package type</p> <p>Sorting Code</p>	

**Part No.**  
 MH255ESD

**Temperature Suffix**  
 E (-40°C to + 85°C)

**Package Type**  
 SD (DFN-6L-2\*2)

*Custom sensitivity selection is available by MST sorting technology*

**Functional Diagram**

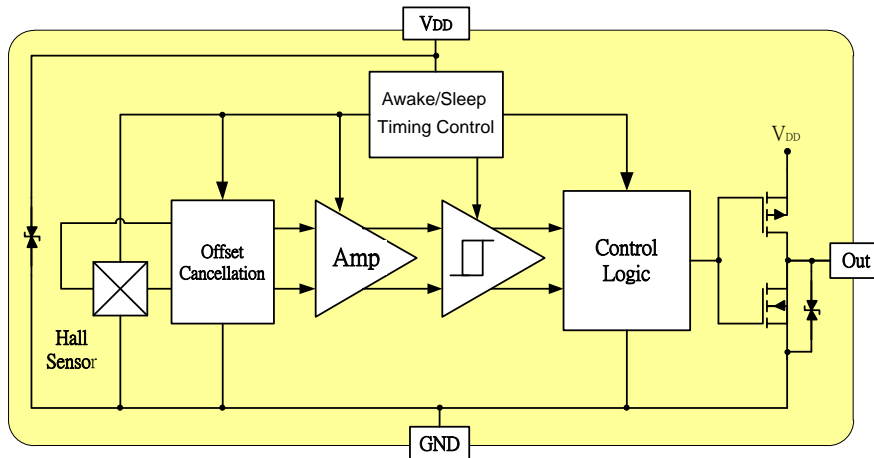

**Note:** Static sensitive device; please observe ESD precautions. Reverse  $V_{DD}$  protection is not included. For reverse voltage protection, a 100 $\Omega$  resistor in series with  $V_{DD}$  is recommended.

**MH 255, HBM**  $\geq \pm 4KV$  which is verified by third party lab.

### Absolute Maximum Ratings At( $T_a=25^{\circ}\text{C}$ )

Characteristics	Values	Unit	
Supply voltage, ( $V_{DD}$ )	7	V	
Output Voltage, ( $V_{out}$ )	7	V	
Reverse Voltage, ( $V_{DD}$ ) ( $V_{out}$ )	-0.3	V	
Magnetic flux density	Unlimited	Gauss	
Output current, ( $I_{out}$ )	1	mA	
Operating temperature range, ( $T_a$ )	-40 to +85	$^{\circ}\text{C}$	
Storage temperature range, ( $T_s$ )	-65 to +150	$^{\circ}\text{C}$	
Maximum Junction Temp, ( $T_j$ )	150	$^{\circ}\text{C}$	
Thermal Resistance	( $\theta_{JA}$ ) SD	160	$^{\circ}\text{C}/\text{W}$
	( $\theta_{JC}$ ) SD	35	$^{\circ}\text{C}/\text{W}$
Package Power Dissipation, ( $P_D$ ) SD	780	mW	

*Note: Exceeding the absolute maximum ratings may cause permanent damage. Exposure to absolute maximum-rated conditions for extended periods may affect device reliability.*

### Electrical Specifications

DC Operating Parameters:  $T_a=25^{\circ}\text{C}$ ,  $V_{DD}=3\text{V}$

Parameters	Test Conditions	Min	Typ	Max	Units
Supply Voltage, ( $V_{DD}$ )	Operating	1.7		5.5	V
Supply Current, ( $I_{DD}$ )	Awake State		1.4	3	mA
	Sleep State		3.6	7	$\mu\text{A}$
	Average		5		$\mu\text{A}$
Output Leakage Current, ( $I_{off}$ )	Output off			1	$\mu\text{A}$
Output High Voltage, ( $V_{OH}$ )	$I_{OUT}=0.5\text{mA}$ (Source)	$V_{DD}-0.2$			V
Output Low Voltage, ( $V_{OL}$ )	$I_{OUT}=0.5\text{mA}$ (Sink)			0.2	V
Awake mode time, ( $T_{aw}$ )	Operating		40	80	$\mu\text{s}$
Sleep mode time, ( $T_{sl}$ )	Operating		40	80	mS
Duty Cycle, ( $D, C$ )			0.1		%
Electro-Static Discharge	HBM	4			KV

### Typical Application circuit

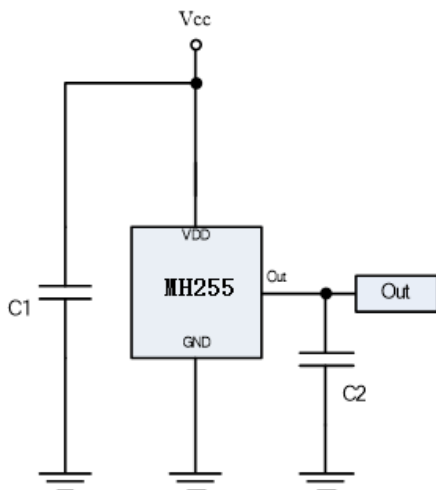

C1 : 10nF

C2 : 100pF

**MH255ESD Magnetic Specifications**

DC Operating Parameters:  $T_a=25^{\circ}C$ ,  $V_{DD}=3V$

Parameter	Symbol	Test Conditions	Min.	Typ.	Max.	Units
Operating Point	BOPS	S pole to branded side, $B > BOP$ , Vout On	20	30	40	Gauss
	BOPN	N pole to branded side, $B > BOP$ , Vout On	-40	-30	-20	Gauss
Release Point	BRPS	S pole to branded side, $B < BRP$ , Vout Off	10	20	30	Gauss
	BRPN	N pole to branded side, $B < BRP$ , Vout Off	-30	-20	-10	Gauss
Hysteresis	BHYS	$ BOPx - BRPx $		10		Gauss

**MH255ESD Output Behavior versus Magnetic Polar**

DC Operating Parameters:  $T_a = -40$  to  $85^{\circ}C$ ,  $V_{dd} = 1.7V$  to  $5.5V$

Parameter	Test condition	OUT
South pole	$B > Bop-S$	Low
Null or weak magnetic field	$B=0$ or $B < BRP$	High
North pole	$B < Bop-N$	Low

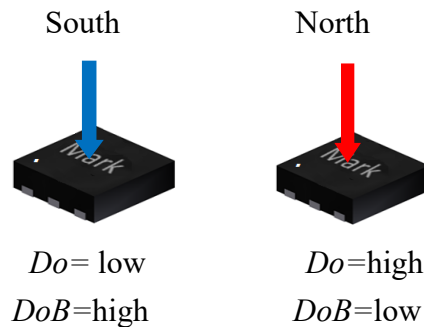

**SD Package**

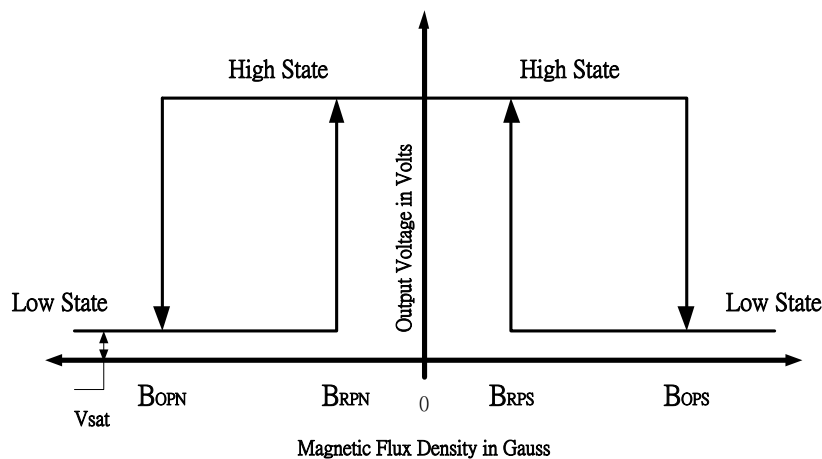

### Performance Graph

Typical Supply Voltage ( $V_{DD}$ ) Versus Flux Density

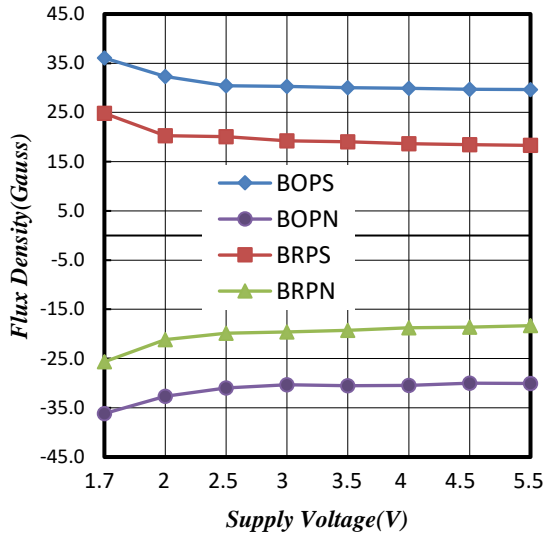

Typical Temperature ( $T_A$ ) Versus Flux Density

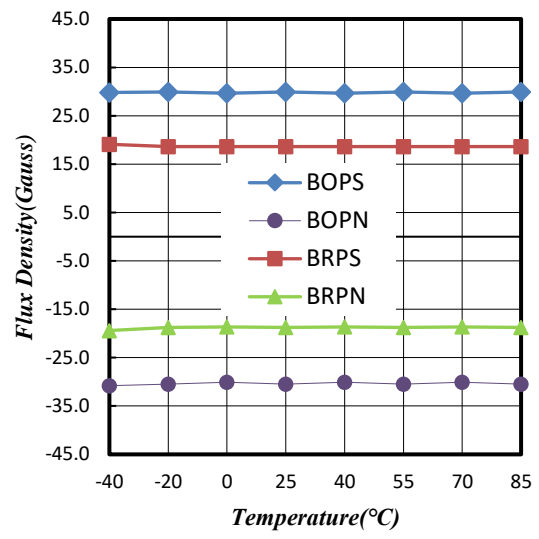

Typical Temperature ( $T_A$ ) Versus Supply Current ( $I_{DD}$ )

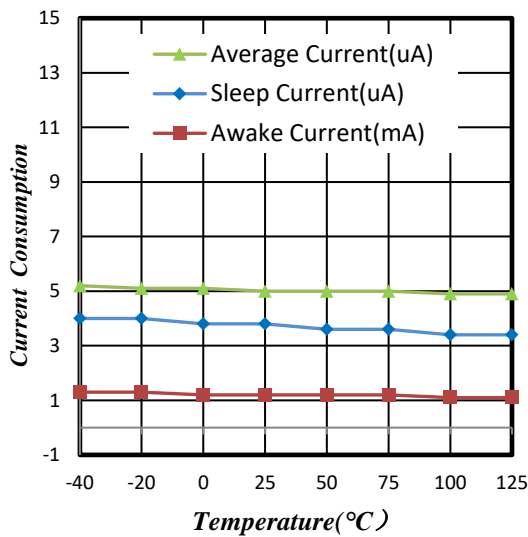

Typical Supply Voltage ( $V_{DD}$ ) Versus Supply Current ( $I_{DD}$ )

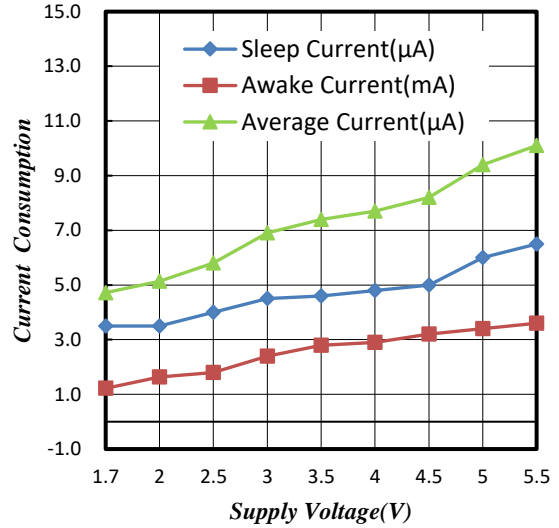

Typical Supply Voltage ( $V_{DD}$ ) Versus Output Voltage ( $V_{DSON}$ )

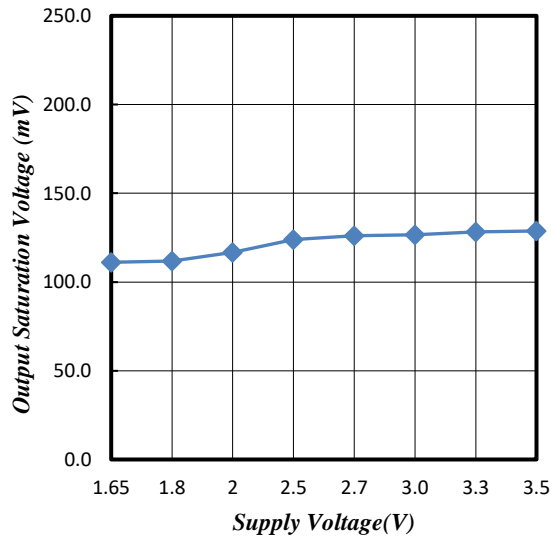

Typical Temperature ( $T_A$ ) Versus Output Voltage ( $V_{DSON}$ )

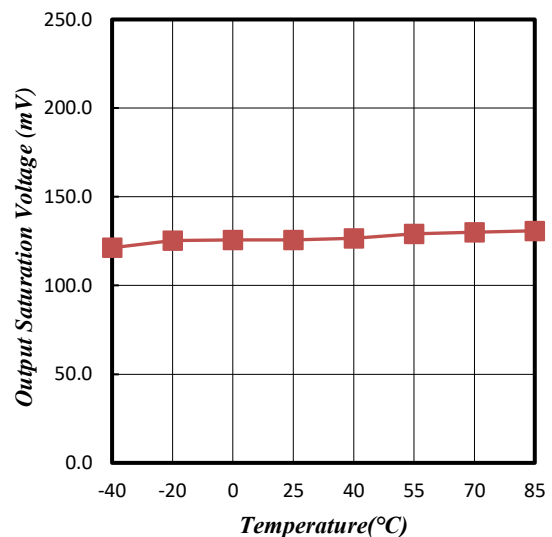

*Typical Supply Voltage ( $V_{DD}$ ) Versus Leakage Current ( $I_{OFF}$ )*

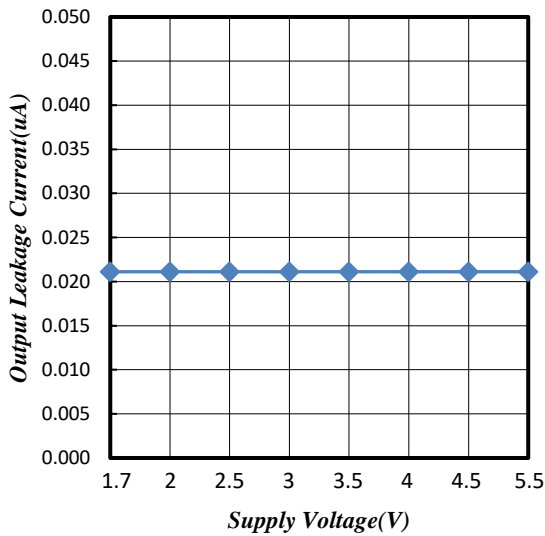

**Package Power Dissipation**

The power dissipation of the Package is a function of the pad size. This can vary from the minimum pad size for soldering to a pad size given for maximum power dissipation. Power dissipation for a surface mount device is determined by  $T_{J(max)}$ , the maximum rated junction temperature of the die,  $R_{\theta JA}$ , the thermal resistance from the device junction to ambient, and the operating temperature,  $T_a$ . Using the values provided on the data sheet for the package, PD can be calculated as follows:

$$P_D = \frac{T_{J(max)} - T_a}{R_{\theta ja}}$$

The values for the equation are found in the maximum ratings table on the data sheet. Substituting these values into the equation for an ambient temperature  $T_a$  of 25°C, one can calculate the power dissipation of the device which in this case is 400 milliwatts.

$$P_D(SD) = \frac{150^\circ\text{C} - 25^\circ\text{C}}{160^\circ\text{C/W}} = 780\text{mW}$$

The 310°C/W for the ST package assumes the use of the recommended footprint on a glass epoxy printed circuit board to achieve a power dissipation of 400 milliwatts. There are other alternatives to achieving higher power dissipation from the Package. Another alternative would be to use a ceramic substrate or an aluminum core board such as Thermal Clad. Using a board material such as Thermal Clad, an aluminum core board, the power dissipation can be doubled using the same footprint.

**Sensor Location, package dimension and marking**

**MH255 Package**

**SD package**

**(Bottom View)**

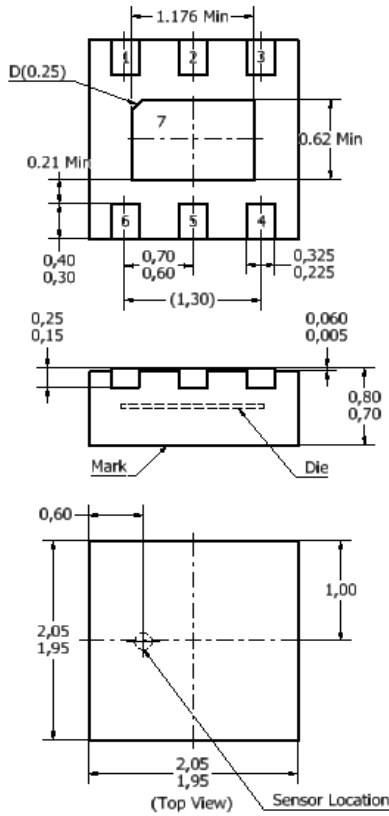

**NOTES:**

1. Controlling dimension: mm
2. Leads must be free of flash and plating voids
3. Lead thickness after solder plating will be 0.254mm maximum
4. PINOUT:

Pin No.	Pin Name
1	VCC
3	Out
5	GND
2、4、6、7	ND

**MH255ESD Package Date Code**

**XX**

Week Code

week	1	2	3	4	5	6	7	8	9	10	11	12	13
code	CA	CB	CC	CD	CE	CF	CG	CH	CI	CJ	CK	CL	CM
week	14	15	16	17	18	19	20	21	22	23	24	25	26
code	CN	CO	CP	CQ	CR	CS	CT	CU	CV	CW	CX	CY	CZ
week	27	28	29	30	31	32	33	34	35	36	37	38	39
code	DA	DB	DC	DD	DE	DF	DG	DH	DI	DJ	DK	DL	DM
week	40	41	42	43	44	45	46	47	48	49	50	51	52
code	DN	DO	DP	DQ	DR	DS	DT	DU	DV	DW	DX	DY	DZ

EX: 2019 Year\_8 Week → CH

**SD Package Tape On Reel Dimension**

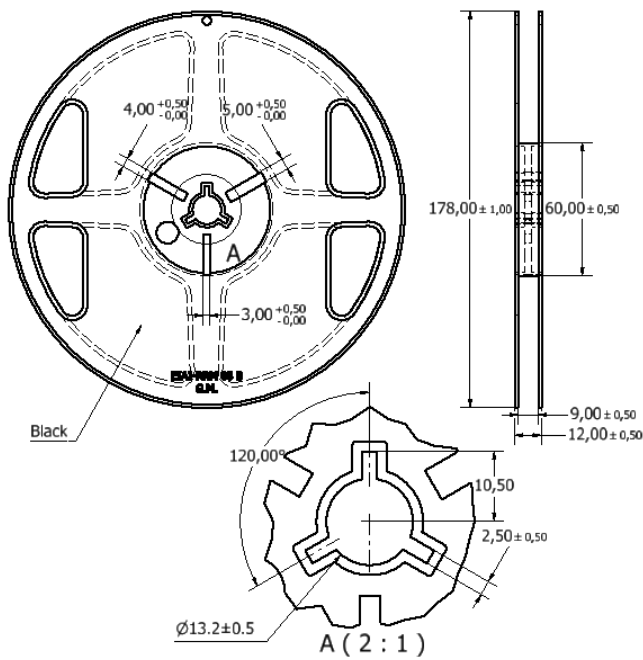
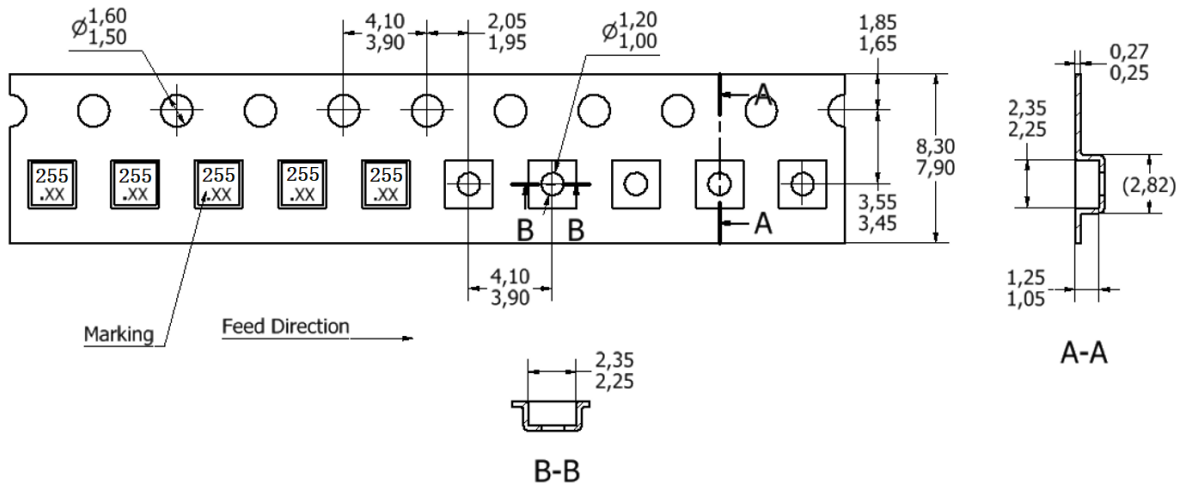

NOTES:

1. Material: Conductive polystyrene;
2. DIM in mm;
3. 10 sprocket hole pitch cumulative tolerance  $\pm 0.2$ ;
4. Camber not to exceed 1mm in 100mm;
5. Pocket position relative to sprocket hole measured as true position of pocket, not pocket hole;
6. (S.R. OHM/SH) Means surface electric resistivity of the carrier tape.



**IR reflow curve**

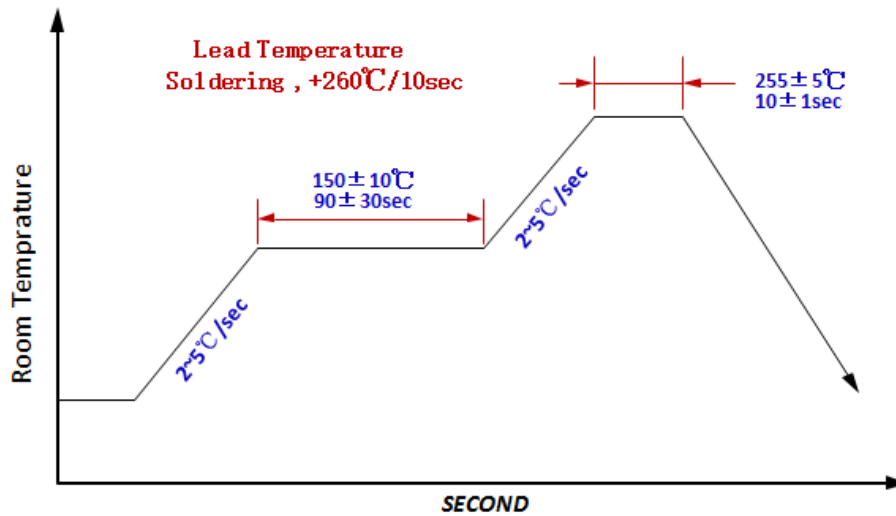

**SD Soldering Condition**

**Packing specification:**

SD(DFN2x2)	Weight
3000pcs/reel	0.10kg
5 reels/box	0.61kg
12 boxes/carton	8.4kg

**SD Package Inner box label : Size: 5cm\*8cm**



**SD Carton label : Size: 6 cm \* 9cm**



**Combine:**

When combine lot, one reel could have two D/C and no more than two DC. One carton could have two devices, no more than two;