



MH 274 Specifications **Pull High Res Omni polar Hall Effect Switch**

MH274 Hall effect switch is a temperature stable, Superior high-temperature performance is made possible through a dynamic offset cancellation that utilizes chopper-stabilization.

MH274 includes the following on a single silicon chip: voltage regulator, Hall voltage generator, small-signal amplifier, chopper stabilization, Schmitt trigger, and 10K ohm resistor integrated output. Advanced DMOS wafer fabrication processing is used to take advantage of low-voltage requirements, component matching, very low input-offset errors, and small component geometries.

This device requires the presence of omni-polar magnetic fields for operation.

MH274 is rated for operation between the ambient temperatures -40°C and $+85^{\circ}\text{C}$ for the E temperature range. and -40°C to $+125^{\circ}\text{C}$ for the K temperature range. The two package styles available provide magnetically optimized solutions for most applications. Package types SO is an SOT-23, a miniature low-profile surface-mount package, while package UA is a three-lead ultra-mini SIP for through-hole mounting.

The package type is in a Halogen Free version was verified by third party Lab.

Features and Benefits

- DMOS Hall IC Technology.
- Operation range from 2.5V to 26V.
- 10K ohm integrated.
- Reverse bias protection on power supply pin.
- High Sensitivity for reed switch replacement applications.
- Low sensitivity drift in crossing of Temp range.
- High ESD Protection, HBM $>\pm 4\text{KV}(\text{min})$
- RoHS compliant 2011/65/EU and Halogen Free

Applications

- Solid state switch.
- Limit switch.
- Magnet proximity sensor
- Position sensor
- Speed sensor
- Rotation sensor
- Counting sensor

Ordering Information

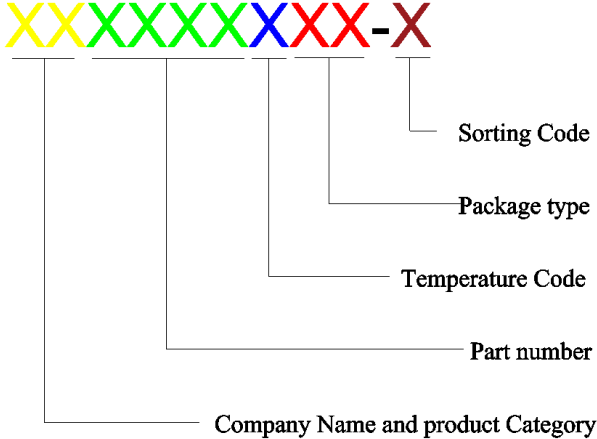
	<p>Company Name and Product Category MH:MST Hall Effect/MP:MST Power MOSFET</p> <p>Part number 181,182,183,184,185,248,249,276,477,381,381F,381R,382.....</p> <p>If part # is just 3 digits, the fourth digit will be omitted.</p> <p>Temperature range E: 85 °C, I: 105 °C, K: 125 °C, L: 150 °C</p> <p>Package type UA:TO-92S,VK:TO-92S(4pin),VF:TO-92S(5pin),SO:SOT-23, SQ:QFN-3,ST:TSOT-23,SN:SOT-553,SF:SOT-89(5pin)</p> <p>Sorting α, β, Blank.....</p>
---	---

Part No.	Temperature Suffix	Package Type
MH274KUA	K (-40°C to + 125°C)	UA (TO-92S)
MH274EUA	E (-40°C to + 85°C)	UA (TO-92S)
MH274KSO	K (-40°C to + 125°C)	SO (SOT-23)
MH274ESO	E (-40°C to + 85°C)	SO (SOT-23)

KUA spec is using in industrial and automotive application. Special Hot Testing is utilized.

Functional Diagram

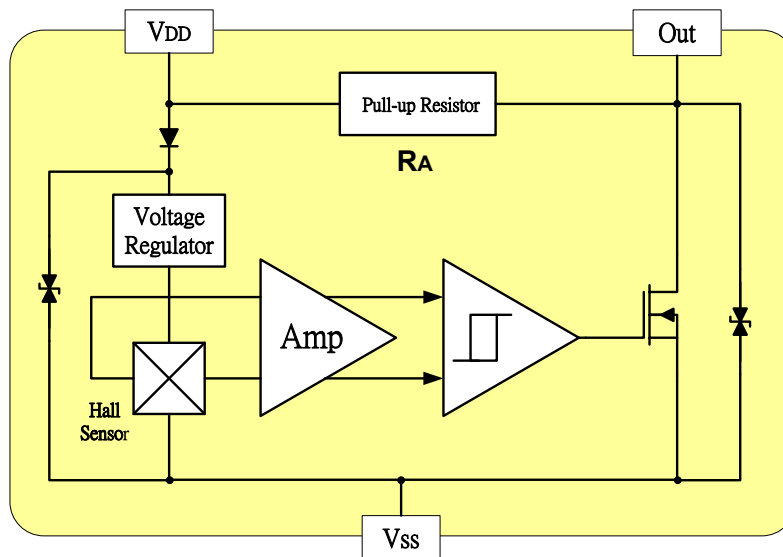

Absolute Maximum Ratings At ($T_a=25^\circ\text{C}$)

Characteristics		Values	Unit
Supply voltage, (V_{DD})		28	V
Output Voltage, (V_{out})		28	V
Reverse Voltage, (V_{DD} / V_{out})		-28/-0.3	V
Output current, (I_{SINK})		25	mA
Operating Temperature Range, (T_A)	“E” Class	-40 ~ +85	$^\circ\text{C}$
	“K” Class	-40 ~ +125	$^\circ\text{C}$
Storage temperature Range, (T_s)		-55 ~ +150	$^\circ\text{C}$
Maximum Junction Temp, (T_j)		150	$^\circ\text{C}$
Thermal Resistance	(θ_{JA}) UA/ SO	206 / 543	$^\circ\text{C}/\text{w}$
	(θ_{JC}) UA/ SO	148 / 410	$^\circ\text{C}/\text{w}$
Package Power Dissipation, (P_D)		606 / 230	mW

Note: Do not apply reverse voltage to V_{DD} and V_{OUT} Pin, It may be caused for Miss function or damaged device.

Electrical Specifications

DC Operating Parameters : $T_A=+25^\circ\text{C}$, $V_{DD}=12\text{V}$

Parameters	Test Conditions	Min	Typ	Max	Units
Supply Voltage, (V_{DD})	Operating	2.5		26.0	V
Supply Current, (I_{DD})	$B < B_{OP}$		2.5	3.5	mA
Output Saturation Voltage, (V_{DSON})	$I_{out}=20\text{mA}, B > B_{OP}$		300		mV
Output Leakage Current, (I_{off})	$I_{OFF} B < B_{RP}, V_{OUT} = 12\text{V}$			10.0	μA
Pull-up Resistor, (R_A)			10		K Ω
Power-On Time, (T_P)				150	μS
Output Switch Time, (T_{SW})				150	μS
Output Switch Frequency, (F_{SW})		3			kHz
Output Rise Time, (T_R)	$R_L=1\text{K}\Omega, C_L=20\text{pF}$			1.0	μS
Output Fall Time, (T_F)	$R_L=1\text{k}\Omega; C_L=20\text{pF}$			1.0	μS
Operate Point, $B_{OPS}(B_{OPN})$	$B > B_{OPS}(B < B_{OPN}), V_{OUT} \text{ On}$	20(-40)	30(-30)	40(-20)	Gauss
Release Point, $BRPS(B_{RPN})$	$B < BRPS(B > BRPN), V_{OUT} \text{ Off}$	11(-36)	20(-20)	36(-11)	Gauss
Hysteresis, (B_{HYS})	$ B_{OP} - B_{RP} $		10		Gauss

Typical application circuit

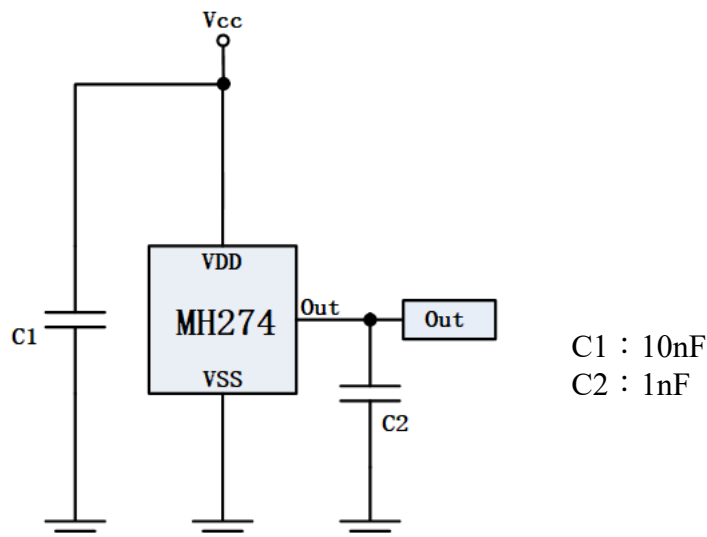

Sensor Location, Package Dimension and Marking

UA Package

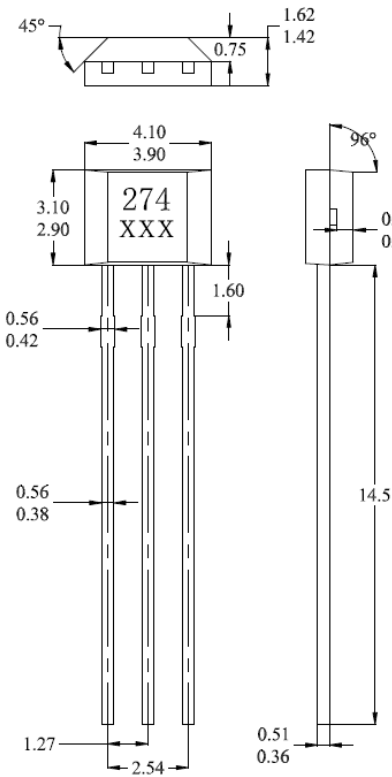

Hall Chip location

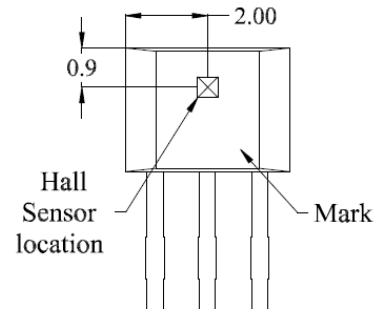

NOTES:

1. Controlling dimension: mm
2. Leads must be free of flash and plating voids
3. Do not bend leads within 1 mm of lead to package interface.
4. PINOUT:
 Pin 1 V_{DD}
 Pin 2 GND
 Pin 3 Output

Output Pin Assignment (Top view)

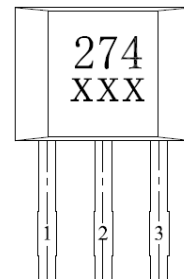

Package (SOT-23) (Top View)

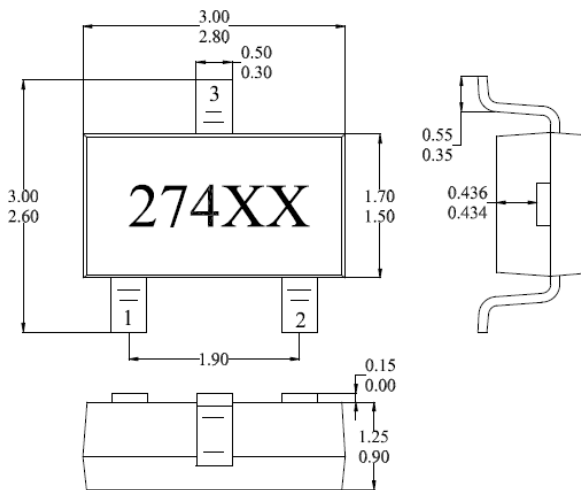

Hall Plate Chip Location (Bottom view)

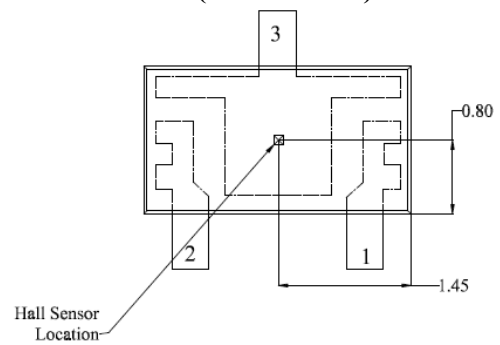

(For reference only) Land Pattern

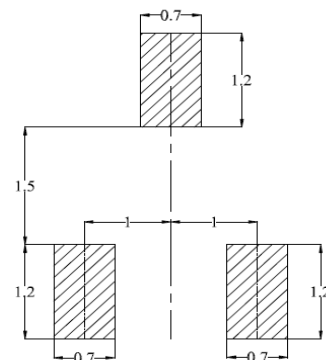

NOTES:

1. PINOUT (See Top View at left :)
 Pin 1 V_{DD}; Pin 2 Output; Pin 3 GND
2. Controlling dimension: mm
3. Lead thickness after solder plating will be 0.254mm maximum