

MH232 Hall-effect sensor is a temperature stable, stress-resistant, Low Tolerance of Sensitivity Ultra-power switch. Superior high-temperature performance is made possible through a dynamic offset cancellation that utilizes chopper-stabilization. This method reduces the offset voltage normally caused by device over molding, temperature dependencies, and thermal stress.

MH232 is special made for low operation voltage, 2.7V, to active the chip which is includes the following on a single silicon chip: voltage regulator, Hall voltage generator, small-signal amplifier, chopper stabilization, Schmitt trigger, CMOS output driver. Advanced CMOS wafer fabrication processing is used to take advantage of low-voltage requirements, component matching, very low input-offset errors, and small component geometries. This device can be operated on not only unipolar S or N, but omnipolar magnetic field.

The package type is in a Halogen Free version has been verified by third party Lab.

Features and Benefits

- CMOS Hall IC Technology
- Strong RF noise protection
- 2.7 to 5.5V for battery-powered applications
- Omni polar, output switches with absolute value of North or South pole from magnet
- Operation down to 2.7V
- High Sensitivity for reed switch replacement applications
- Low sensitivity drift in crossing of Temp. range
- Ultra low power consumption at 1.6uA (Avg)
- High ESD Protection, HBM > ±4KV(min)
- Operation with South Pole (OUT1) or North Pole (OUT2)
- Totem-pole output
- RoHS compliant 2011/65/EU and Halogen Free

Applications

- Solid state switch
- Magnet proximity sensor for reed switch replacement in low duty cycle applications
- Water Meter
- PDA
- NB
- Tab PC
- Security
- Smart meter
- 3C

Ordering Information

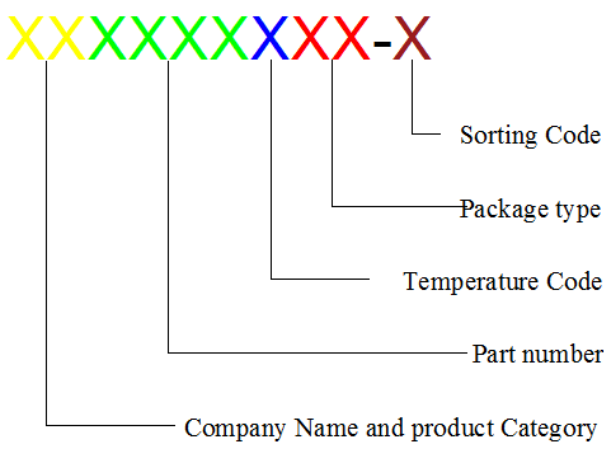
	<p>Company Name and Product Category MH:MST Hall Effect/MP:MST Power MOSFET</p> <p>Part number 181,182,183,184,185,248,249,276,477,381,381F,381R,382..... If part # is just 3 digits, the fourth digit will be omitted.</p> <p>Temperature range E: 85 °C, I: 105 °C, K: 125 °C, L: 150 °C</p> <p>Package type UA:TO-92S,VK:TO-92S(4pin),VF:TO-92S(5pin),SO:SOT-23, SQ:QFN-3,ST:TSOT-23,SN:SOT-553,SF:SOT-89(5pin)</p> <p>Sorting α, β, Blank.....</p>
---	--

Part No.	Temperature Suffix	Package Type
MH232ESD	E(-40°C to +85°C)	SD (DFN2x2-6L)
MH232ESS	E (-40°C to + 85°C)	SS (DFN1x1-4L)

Custom sensitivity selection is available by MST sorting technology

Functional Diagram

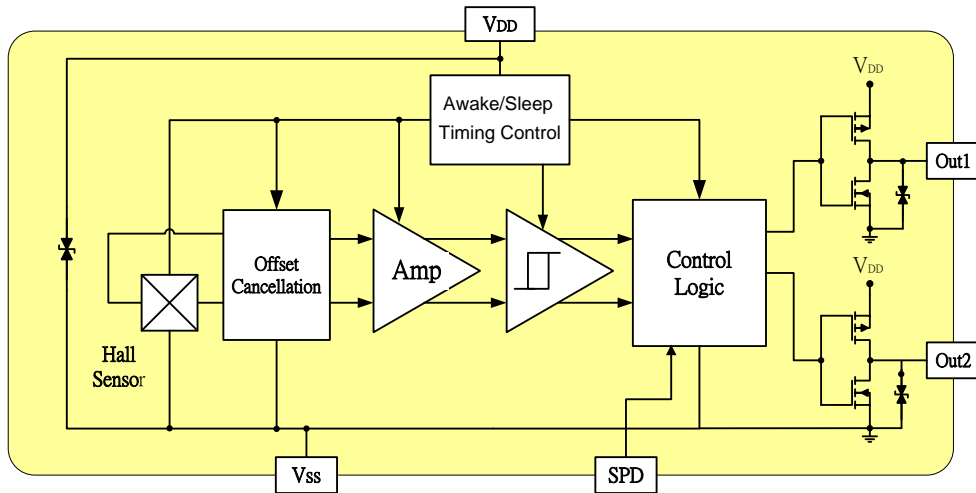

Note: Static sensitive device; please observe ESD precautions. Reverse V_{DD} protection is not included. For reverse voltage protection, a 100 Ω resistor in series with V_{DD} is recommended.

MH232, HBM > $\pm 4KV$ which is verified by third party lab.

Absolute Maximum Ratings At($T_a=25^{\circ}\text{C}$)

Characteristics	Values	Unit
Supply voltage, (V_{DD})	6.0	V
Output Voltage, (V_{out})	6.0	V
Magnetic flux density	Unlimited	Gauss
Output current, (I_{OUT})	5	mA
Operating temperature range, (T_a)	-40 to +85	$^{\circ}\text{C}$
Storage temperature range, (T_s)	-65 to +150	$^{\circ}\text{C}$
Maximum Junction Temp, (T_j)	150	$^{\circ}\text{C}$
Package Power Dissipation, (P_D) SS/SD	416/ 780	mW

Note: Exceeding the absolute maximum ratings may cause permanent damage. Exposure to absolute maximum-rated conditions for extended periods may affect device reliability.

Electrical Specifications

DC Operating Parameters : $T_a=25^{\circ}\text{C}$, $V_{DD}=3.0\text{V}$

Parameters	Test Conditions	Min	Typ	Max	Units
Supply Voltage, (V_{DD})	Operating	2.7		5.5	V
Supply Current, (I_{DD})	Awake State		1.2		mA
	Sleep State		1.3		μA
	Average (SPD=Hi)		1.6/(135)		μA
Output High Voltage, (V_{OH})	$I_{OUT}=1.0\text{mA}$ (Source)	$V_{DD}-0.2$			V
Output Low Voltage, (V_{OL})	$I_{OUT}=1.0\text{mA}$ (Sink)			0.2	V
Awake mode time, (T_{aw})	Operating		16		μs
Sleep mode time, (T_{SL})	Operating (SPD=Hi)		64/(0.128)		mS
Duty Cycle, (D, C)	(SPD=Hi)		0.025/(12.5)		%
Power-On Time, (T_{PO})	(SPD=Hi)		64(0.128)		mS
Output Switch Time, (T_{SW})	Operating (SPD=Hi)		64(0.128)		mS
Output Switch Frequency, (F_{SW})	Operating (SPD=Hi)	15(6.5k)			Hz
Electro-Static Discharge	HBM	4			KV
Operate Point, BOPS(Output1)	$B > \text{BOPS}$,	20		55	Gauss
Release Point, BRPS(Output1)	$B < \text{BRPS}$,	10		45	Gauss
Operate Point, BOPN(Output2)	$B < \text{BOPN}$,	-55		-20	Gauss
Release Point, BRPN(Output2)	$B > \text{BRPN}$,	-45		-10	Gauss
Hysteresis, (BHYS)	$ \text{BOPX} - \text{BRPX} $		10		Gauss

MH232ESS/SD Output Behavior versus Magnetic Polar

DC Operating Parameters : $T_a = -40$ to 85°C , $V_{DD} = 2.7\text{V}$ to 5.5V

Parameter	Test condition	OUT1	Test condition	OUT2
South pole	$B > B_{OPS}$	Low	--	High
Null or weak magnetic field	$B=0$ or $B < B_{RPS}$	High	$B=0$ or $B > B_{RPN}$	High
North pole	--	High	$B < B_{OPN}$	Low

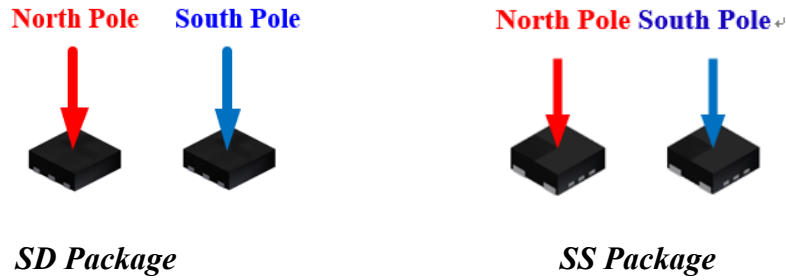

Output Behavior

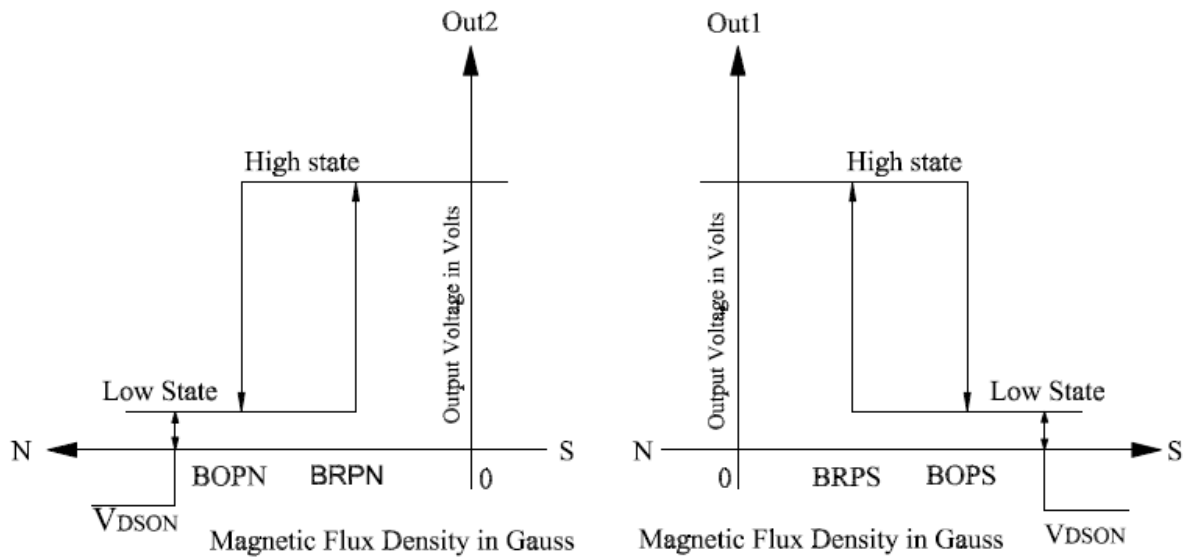

Typical application circuit

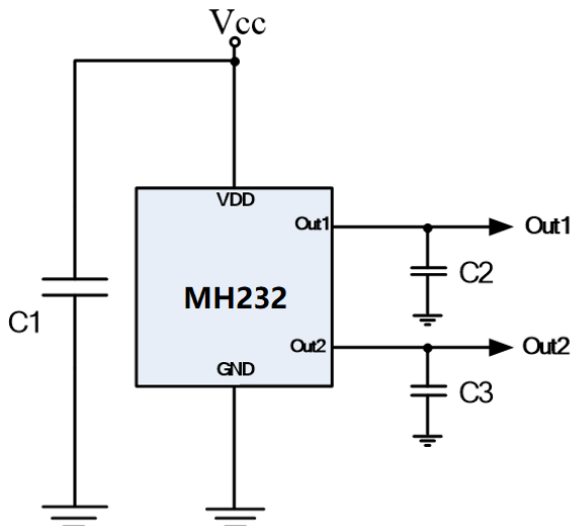

- C1 : 10nF
- C2 : 100pF
- C3 : 100pF

Sensor Location, package dimension and marking

SS Package (DFN 1.0*1.0-4L)

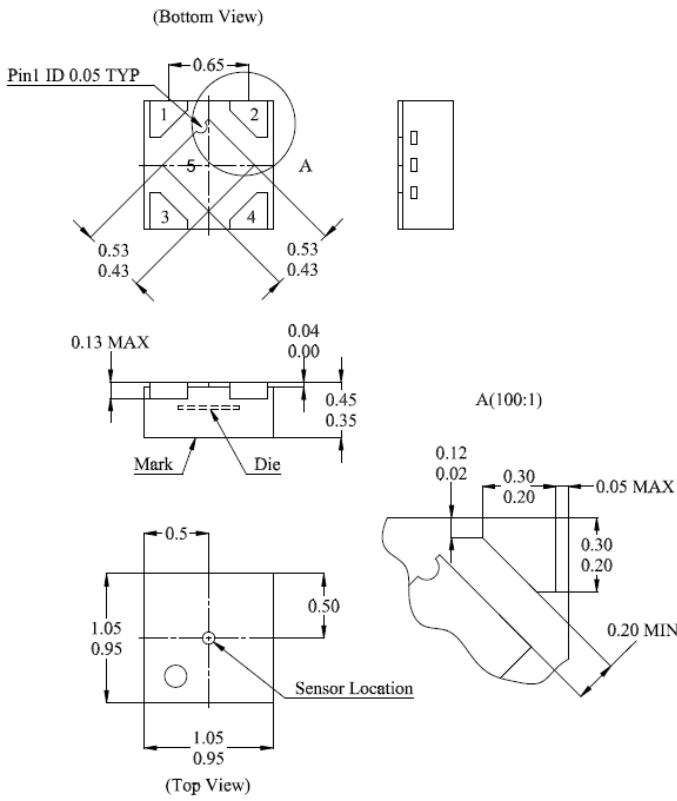

NOTES:

Controlling dimension: mm

1. Leads must be free of flash and plating voids
2. Lead thickness after solder plating will be 0.254mm maximum
3. PINOUT:

Pin No.	Pin Name	Function
1	V _{DD}	Power Supply
2	V _{SS}	Ground
3	S V _{OUT}	Output1
4	N V _{OUT}	Output2
5	PAD	NC

4. (For reference only) Land pattern

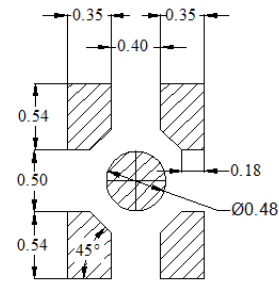

SD package (DFN2*2-6L)

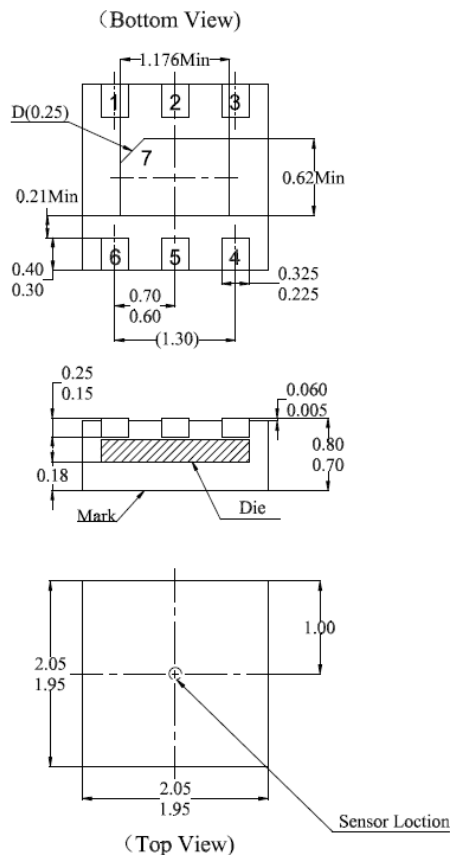

NOTES:

Controlling dimension: mm

1. Leads must be free of flash and plating voids
2. Lead thickness after solder plating will be 0.254mm maximum
3. PINOUT:

Pin No.	Pin Name	Function
1	V _{DD}	Power Supply
2	N V _{OUT}	Output2
3	S V _{OUT}	Output1
4	N.C	N.C
5	V _{SS}	Ground
6	SPD	Set pin
7	PAD	Ground

4. (For reference only) Land pattern

