

MH49A1, sensitivity adjustable of linear Hall-effect sensor, is composed of Hall sensor, linear amplifier and Totem-Pole output stage. It features low noise output, which use an external capacitance. It also can provide increased temperature stability and accuracy. The linear Hall sensor has a wide operating temperature range of -40°C to +125°C, appropriate for commercial, consumer, and industrial environments.

The high sensitivity of Hall-effect sensor accurately tracks extremely weak changes in magnetic flux density. The linear sourcing output voltage is set by the supply voltage and in proportion of vary of the magnetic flux density. That is proportional to the applied magnetics and features a null voltage output of half of the applied voltage.

The SD package is an ultra-mini SMD in SMT process.

Features and Benefits

- Wide operating Voltage 2.8V~6.0V
- Power consumption of 3.3mA at 5 VDC for energy efficiency
- sensitivity adjustable
- Low-Noise output
- Linear output for circuit design flexibility
- Totem-Pole for a stable and accurate output
- Responds to either positive or negative gauss
- Robust ESD performance
- Optional ultra-mini package
- RoHS compliant 2011/65/EU and Halogen Free

Applications

- Current sensing
- Motor control
- Position sensing
- Vibration sensing
- Liquid level sensing
- Weight sensing
- Magnetic code reading
- Rotary encoder
- Ferrous metal detector

Ordering Information

	<p>Company Name and Product Category MH:MST Hall Effect/MP:MST Power IC</p> <p>Part number 181,D182,183,184,185,248,477,D381,D381F,381R,D382..... If part # is just 3 digits, the fourth digit will be omitted.</p> <p>Temperature range E: 85 °C, I: 105 °C, K: 125 °C, L: 150 °C</p> <p>Package type UA:TO-92S,VK:TO-92S(4pin),VF:TO-92S(5pin),SO:SOT-23, SQ:QFN-3,ST:TSOT-23,SN:SOT-553,SF:SOT-89(5pin), SS:TSOT-26,SD:DFN-6,SG:SOT-89(3pin)</p> <p>Sorting α,β,Blank.....</p>
<p>Sorting Code</p> <p>Package type</p> <p>Temperature Code</p> <p>Part number</p> <p>Company Name and product Category</p>	

Part No.	Temperature Suffix	Package Type
MH49A1ESD	E (-40°C to +85°C)	SD(DFN2020-6L)
MH49A1KSD	K (-40°C to +125°C)	SD(DFN2020-6L)

Functional Diagram

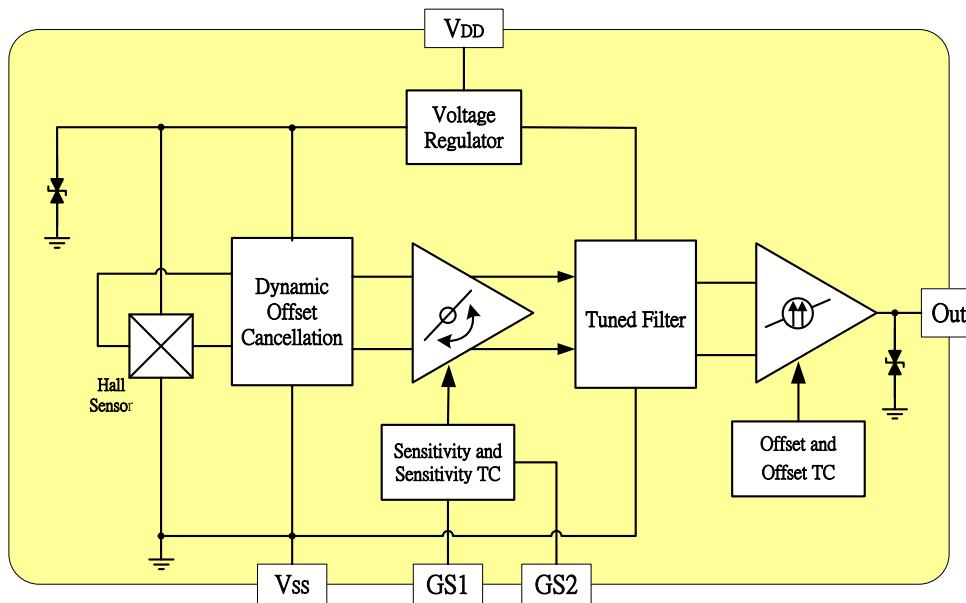

Absolute Maximum Ratings At ($T_a=25^\circ\text{C}$)

Characteristics		Values	Unit
Supply Voltage (V_{DD})		8	V
Reverse Voltage, (V_{DDR})		-0.5	V
Output Voltage, (V_{out})		8	V
Output current, (I_{OUT})		5	mA
Operating Temperature Range, (T_A)	“E” Class	-40 ~ +85	°C
	“K” Class	-40 ~ +125	
Storage temperature Range, (T_S)		-65 ~ +150	°C
Maximum Junction Temp (T_J)		150	°C
Thermal Resistance	(θ_{JA}) SD	160	°C/W
	(θ_{JC}) SD	35	
Package Power Dissipation, (PD)		SD	mW

Note: Do not apply reverse voltage to V_{DD} and V_{OUT} Pin, It may be caused for Miss function or damaged device.

Electrical Specifications

DC Operating Parameters : $T_A=+25^\circ\text{C}$, $V_{CC}=5.0V$

Parameters	Test Conditions	Min	Typ	Max	Units
Supply Voltage, (V_{DD})	Operating	2.8		6.0	V
Supply Current, (I_{DD})	B= 0 Gauss			5.0	mA
Output Current, (I_O)	$V_{DD}>3V$	1.0	1.5		mA
Null Output Voltage, (V_{NULL})	B= 0 Gauss	2.475	2.5	2.525	V
High Output Voltage, (V_{OH})	B> Max Magnetic Gauss		4.9	4.99	V
Low Output Voltage, (V_{OL})	B> Min Magnetic Gauss	0.01	0.1		V
Output Voltage Span, (V_{OS})			4.8		V
Output Referred Noise, (V_{ON})	$T_a=25^\circ\text{C}$, output open		20		mV
Power-On Time, (T_P)				100	uS
Output Switch Time, (T_{SW})				150	uS
Output Switch Frequency, (F_{SW})		3			kHz
Magnetic Range Gauss		± 800		± 1600	Gauss
Ratiometry Null output error, (R_{VON})	Operating voltage range relative to 5V		± 1.5		%
Ratiometry Sensitivity error, (R_{SEN})	Operating voltage range relative to 5V		± 1.5		%
Linearity, (LIN)	% of Span		± 1.5		%
Sensitivity	GS1=Low 、GS2=Open	1.38	1.5	1.62	mV/G
	GS1=Open 、GS2=Open	1.84	2.0	2.16	mV/G
	GS1=Low 、GS2=Low	2.30	2.5	2.68	mV/G
	GS1=Open 、GS2=Low	2.76	3.0	3.24	mV/G
Sensitivity Temperature Coefficient, (TC_{Sens})	$T_a=125^\circ\text{C}$, relative to Sens@ 25°C		± 0.1		%/°C
Delta null voltage, (ΔV_{ON})	$T_a=125^\circ\text{C}$, relative to V_{ON} @ 25°C		20		mV
Electro-Static Discharge	HBM	4			KV

Typical application circuit

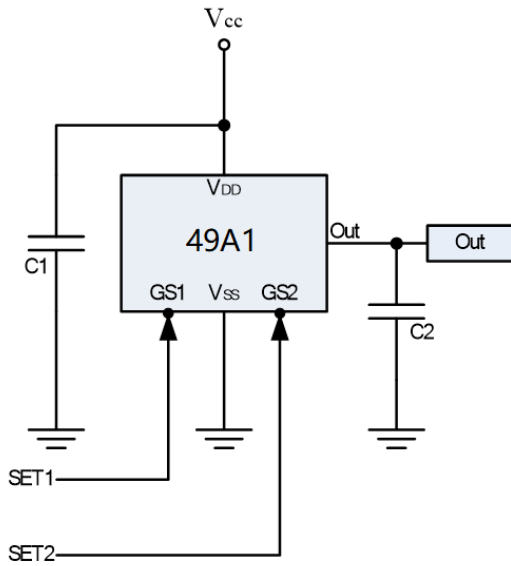

C1 : 1nF/10V
C2 : 10nF/10V

Sensor Location, Package Dimension and Marking

SD Package

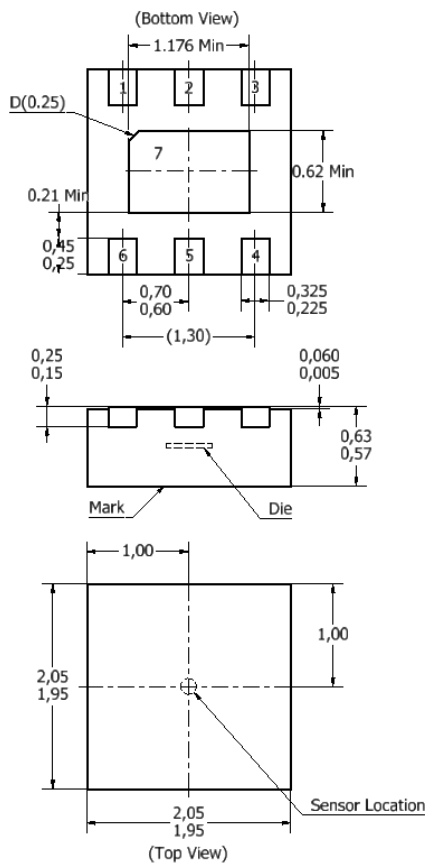

NOTES:

- Controlling dimension: mm
- Leads must be free of flash and plating voids
- Lead thickness after solder plating will be 0.254mm maximum
- Mark:4A1XX; XX:Date Code, Refer to DC table
- PINOUT:

Pin No.	Pin Name	Function
1	VDD	Power Supply
2, 7	NC	NC
3	OUT	Output
4	GS1	Set1 Input
5	VSS	Ground
6	GS2	Set2 Input

- (For reference only) Land Pattern

