

MH274 Hall effect switch is a temperature stable, Superior high-temperature performance is made possible through a dynamic offset cancellation that utilizes chopper-stabilization.

MH274 includes the following on a single silicon chip: voltage regulator, Hall voltage generator, small-signal amplifier, chopper stabilization, Schmitt trigger, and 10K ohm resistor integrated output. Advanced DMOS wafer fabrication processing is used to take advantage of low-voltage requirements, component matching, very low input-offset errors, and small component geometries.

This device requires the presence of omni-polar magnetic fields for operation.

MH274 is rated for operation between the ambient temperatures  $-40^{\circ}\text{C}$  and  $+85^{\circ}\text{C}$  for the E temperature range. and  $-40^{\circ}\text{C}$  to  $+125^{\circ}\text{C}$  for the K temperature range. The two package styles available provide magnetically optimized solutions for most applications. Package types SO is an SOT-23, a miniature low-profile surface-mount package, while package UA is a three-lead ultra-mini SIP for through-hole mounting.

The package type is in a Halogen Free version was verified by third party Lab.

### ***Features and Benefits***

- DMOS Hall IC Technology.
- Operation range from 2.5V to 26V .
- Omni polar, output switches with absolute value of North or South pole from magnet.
- High Sensitivity for reed switch replacement applications.
- Low sensitivity drift in crossing of Temp range.
- High ESD Protection, HBM  $> \pm 4\text{KV}$ ( min )
- Output Current limit in 100mA.
- RoHS compliant 2011/65/EU and Halogen Free

### ***Applications***

- Solid state switch.
- Limit switch.
- Current limit.
- Interrupter.
- Current sensing.
- Magnet proximity sensor for reed switch replacement.

**Ordering Information**

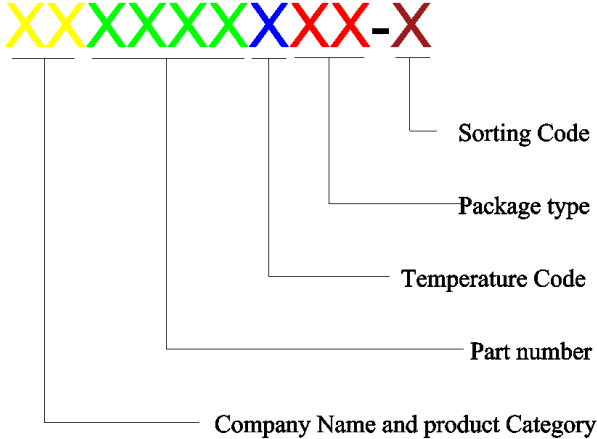
	<p><b>Company Name and Product Category</b> MH:MST Hall Effect/MP:MST Power MOSFET</p> <p><b>Part number</b> 181,182,183,184,185,248,249,276,477,381,381F,381R,382..... If part # is just 3 digits, the forth digit will be omitted.</p> <p><b>Temperature range</b> E: 85 °C, I: 105 °C, K: 125 °C, L: 150 °C</p> <p><b>Package type</b> UA:TO-92S,VK:TO-92S(4pin),VF:TO-92S(5pin),SO:SOT-23, SQ:QFN-3,ST:TSOT-23,SN:SOT-553,SF:SOT-89(5pin)</p> <p><b>Sorting</b> α,β,Blank.....</p>
---	--

Part No.	Temperature Suffix	Package Type
MH274KUA	K (-40°C to + 125°C)	UA (TO-92S)
MH274EUA	E (-40°C to + 85°C)	UA (TO-92S)
MH274KSO	K (-40°C to + 125°C)	SO (SOT-23)
MH274ESO	E (-40°C to + 85°C)	SO (SOT-23)

*KUA spec is using in industrial and automotive application. Special Hot Testing is utilized.*

**Functional Diagram**

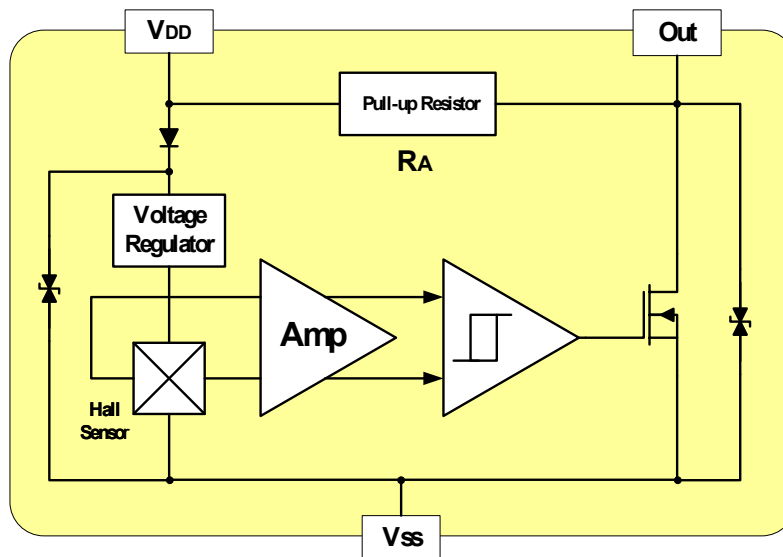

### Absolute Maximum Ratings At ( $T_a=25^\circ\text{C}$ )

Characteristics		Values	Unit
Supply voltage, ( $V_{DD}$ )		28	V
Output Voltage, ( $V_{out}$ )		28	V
Reverse Voltage, ( $V_{DD} / V_{out}$ )		-0.3/-0.3	V
Output current, ( $I_{SINK}$ )		25	mA
Operating Temperature Range, ( $T_A$ )	“E” Class	-40 ~ +85	$^\circ\text{C}$
	“K” Class	-40 ~ +125	$^\circ\text{C}$
Storage temperature Range, ( $T_s$ )		-55 ~ +150	$^\circ\text{C}$
Maximum Junction Temp, ( $T_j$ )		150	$^\circ\text{C}$
Thermal Resistance	( $\theta_{JA}$ ) UA/ SO	206 / 543	$^\circ\text{C}/\text{w}$
	( $\theta_{JC}$ ) UA/ SO	148 / 410	$^\circ\text{C}/\text{w}$
Package Power Dissipation, ( $P_D$ )		606 / 230	mW

**Note:** Do not apply reverse voltage to  $V_{DD}$  and  $V_{OUT}$  Pin, It may be caused for Miss function or damaged device.

### Electrical Specifications

DC Operating Parameters :  $T_A=+25^\circ\text{C}$ ,  $V_{DD}=12\text{V}$

Parameters	Test Conditions	Min	Typ	Max	Units
Supply Voltage, ( $V_{DD}$ )	Operating	2.5		26.0	V
Supply Current, ( $I_{DD}$ )	$B < B_{OP}$		2.5	3.5	mA
Output Saturation Voltage, ( $V_{DSON}$ )	$I_{out}=20\text{mA}, B > B_{OP}$		300		mV
Output Leakage Current, ( $I_{off}$ )	$I_{OFF} B < B_{RP}, V_{OUT} = 12\text{V}$			10.0	$\mu\text{A}$
Output Limited Current, ( $I_{CO}$ )	$B > B_{OP}$		100		mA
Power-On Time, ( $T_{PO}$ )	Power-On			100	$\mu\text{s}$
Output Switch Time, ( $T_{SW}$ )	Operating			100	$\mu\text{s}$
Output Switch Frequency, ( $F_{SW}$ )	Operating	5			kHz
Output Rise Time, ( $T_R$ )	$C_L = 20\text{pF}$		0.1	0.45	$\mu\text{s}$
Output Fall Time, ( $T_F$ )	$C_L = 20\text{pF}$		6.0	10	$\mu\text{s}$
Electro-Static Discharge	HBM	4			KV
Pull-up Resistor, ( $R_A$ )			10		$\text{K}\Omega$
Operate Point, $B_{OPS}(B_{OPN})$	$B > B_{OPS}(B < B_{OPN}), V_{OUT}$ On	20(-55)		55(-20)	Gauss
Release Point, $B_{RPS}(B_{RPN})$	$B < B_{RPS}(B > B_{RPN}), V_{OUT}$ Off	10(-45)		45(-10)	Gauss
Hysteresis, ( $B_{HYS}$ )	$ B_{OPX} - B_{RPX} $		10		Gauss

### Typical application circuit

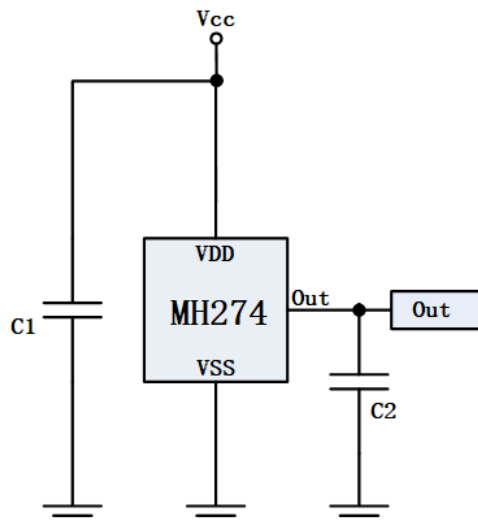

C1 : 10nF  
C2 : 1nF

**Sensor Location, Package Dimension and Marking**

**UA Package**

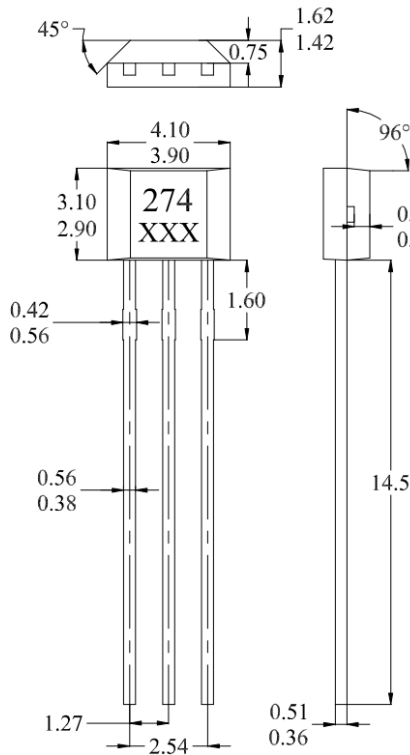

**Hall Chip location**

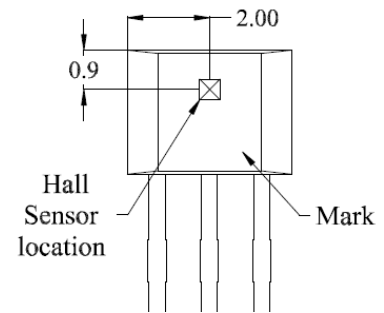

**NOTES:**

1. Controlling dimension: mm
2. Leads must be free of flash and plating voids
3. Do not bend leads within 1 mm of lead to package interface.
4. PINOUT:  
Pin 1 VDD  
Pin 2 GND  
Pin 3 Output
5. XXX; 1<sup>st</sup> X=Year;  
2<sup>nd</sup> and 3<sup>rd</sup> XX=Week

**Output Pin Assignment**

**(Top view)**

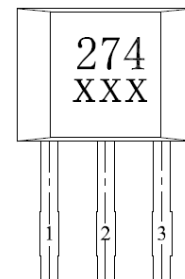

**Package (SOT-23)**

**(Top View)**

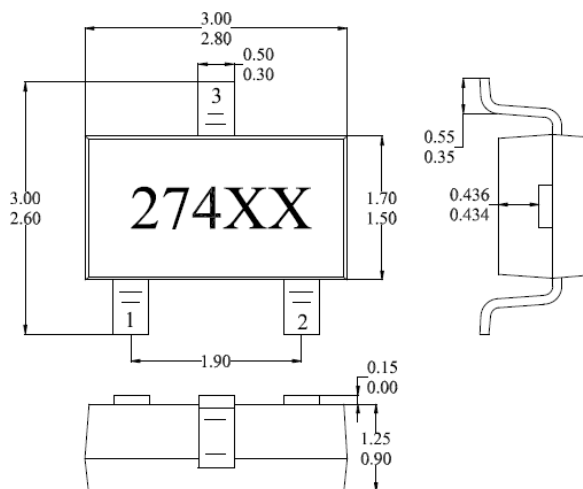

**Hall Plate Chip Location**

**(Bottom view)**

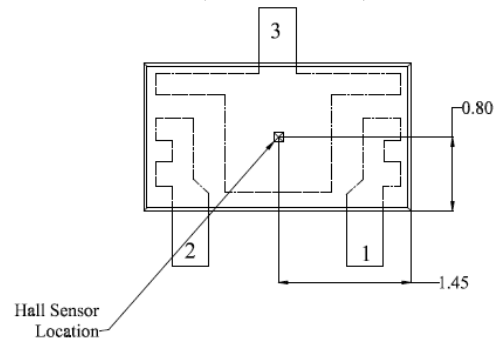

**(For reference only) Land Pattern**

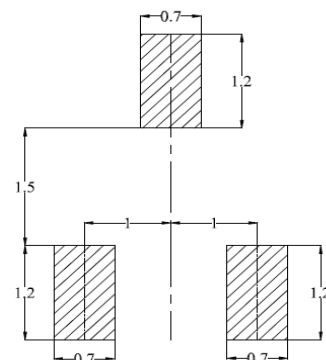

**NOTES:**

1. PINOUT (See Top View at left :)  
Pin 1 V<sub>DD</sub>; Pin 2 Output; Pin 3 GND
2. Controlling dimension: mm
3. Lead thickness after solder plating will be 0.254mm maximum
4. XX: Date Code, Refer to DC table