

MH238 Hall-effect sensor is a temperature stable, stress-resistant, Low Tolerance of Sensitivity nano-power switch. Superior high-temperature performance is made possible through a dynamic offset cancellation that utilizes chopper-stabilization. This method reduces the offset voltage normally caused by device over molding, temperature dependencies, and thermal stress.

MH238 includes the following on a single silicon chip: voltage regulator, Hall voltage generator, small-signal amplifier, chopper stabilization, Schmitt trigger, open-drain output. Advanced CMOS wafer fabrication processing is used to take advantage of low-voltage requirements, component matching, very low input-offset errors, and small component geometries.

The package type is in a Halogen Free version has been verified by third party Lab.

Features and Benefits

- CMOS Hall IC Technology
- Strong RF noise protection
- 1.65 to 5.5V for battery-powered applications
- Omni polar, output switches with absolute value of North or South pole from magnet
- Operation down to 1.65V, Nano power consumption
- High Sensitivity for reed switch replacement applications
- Multi Small Size option
- Low sensitivity drift in crossing of Temp. range
- Ultra Low power consumption at 900nA (Avg)
- High ESD Protection, HBM >±8KV(min)
- RoHS compliant 2011/65/EU and Halogen Free.

Applications

- Solid state switch
- Handheld Wireless Handset Awake Switch (Flip Cell/PHS Phone/Note Book/Flip Video Set)
- Lid close sensor for battery powered devices
- Magnet proximity sensor for reed switch replacement in low duty cycle applications
- Water Meter
- Floating Meter
- PDVD
- NB

Ordering Information

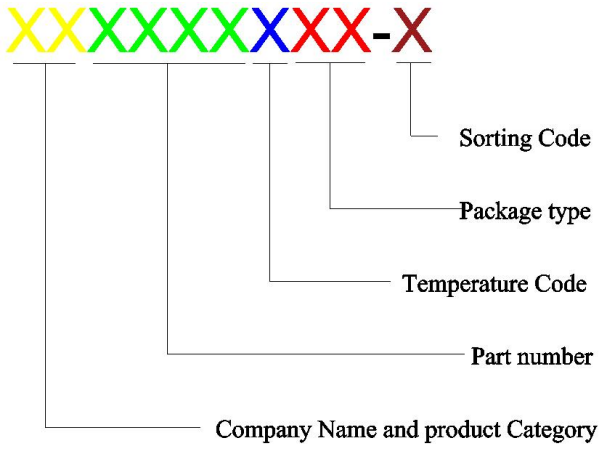
	<p>Company Name and Product Category MH:MST Hall Effect/MP:MST Power IC</p> <p>Part number 181,182,183,184,185,248,249,276,477,381,381F,381R,382..... If part # is just 3 digits, the fourth digit will be omitted.</p> <p>Temperature range E: 85 °C, I: 105 °C, K: 125 °C, L: 150 °C</p> <p>Package type UA:TO-92S,VK:TO-92S(4pin),VF:TO-92S(5pin),SO:SOT-23, SQ:QFN-3,ST:TSOT-23,SN:SOT-553,SF:SOT-89(5pin), SS:TSOT-26,SD:DFN-6;</p> <p>Sorting α,β,Blank.....</p>
---	---

Part No.	Temperature Suffix	Package Type
MH238EUA	E (-40°C to + 85°C)	UA (TO-92S)
MH238ESO	E (-40°C to + 85°C)	SO (SOT-23)
MH238ESM	E (-40°C to + 85°C)	SM (DFN1.6*1.6-6L)

Custom sensitivity selection is available by MST sorting technology

Functional Diagram

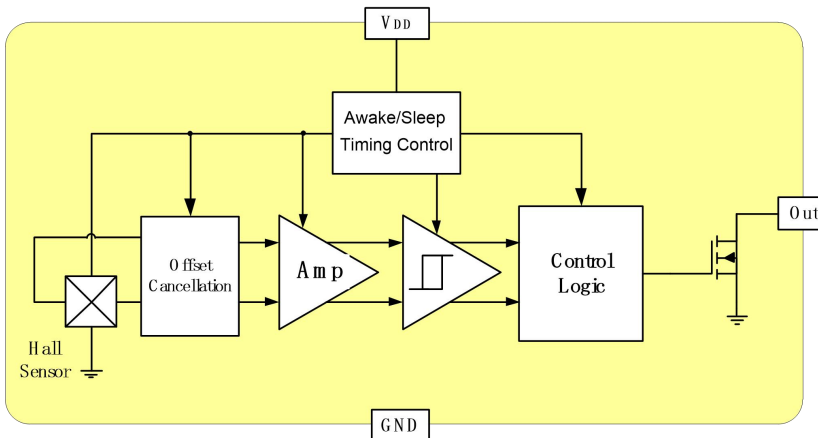

Note: Static sensitive device; please observe ESD precautions. Reverse V_{DD} protection is not included. For reverse voltage protection, a 100 Ω resistor in series with V_{DD} is recommended.

MH238, HBM >±8KV which is verified by third party lab.

Absolute Maximum Ratings At($T_a=25^{\circ}\text{C}$)

Characteristics	Values	Unit
Supply voltage, (V_{DD})	6	V
Output Voltage, (V_{out})	6	V
Reverse Voltage, (V_{DD}) (V_{OUT})	-0.3	V
Magnetic flux density	Unlimited	Gauss
Output current, (I_{out})	10	mA
Operating temperature range, (T_a)	-40 to +85	$^{\circ}\text{C}$
Storage temperature range, (T_s)	-65 to +150	$^{\circ}\text{C}$
Maximum Junction Temp, (T_j)	150	$^{\circ}\text{C}$

Note: Exceeding the absolute maximum ratings may cause permanent damage. Exposure to absolute maximum-rated conditions for extended periods may affect device reliability.

Electrical Specifications

DC Operating Parameters: $T_a=25^{\circ}\text{C}$, $V_{DD}=3.0\text{V}$

Parameters	Test Conditions	Min	Typ	Max	Units
Supply Voltage, (V_{DD})	Operating	1.65		5.5	V
Supply Current, (I_{DD})	Average		900		nA
Output Leakage Current, (I_{off})	Output off			0.1	μA
Output High Voltage, (V_{OH})	$I_{OUT}=0.5\text{mA}$ (Source)	$V_{DD}-0.2$			V
Output Low Voltage, (V_{OL})	$I_{OUT}=0.5\text{mA}$ (Sink)			0.2	V
Awake mode time, (T_{aw})	Operating		25	80	μs
Sleep mode time, (T_{sl})	Operating		35	80	mS
Sampling period			35		mS
Electro-Static Discharge	HBM	8			KV

Typical Application Circuit

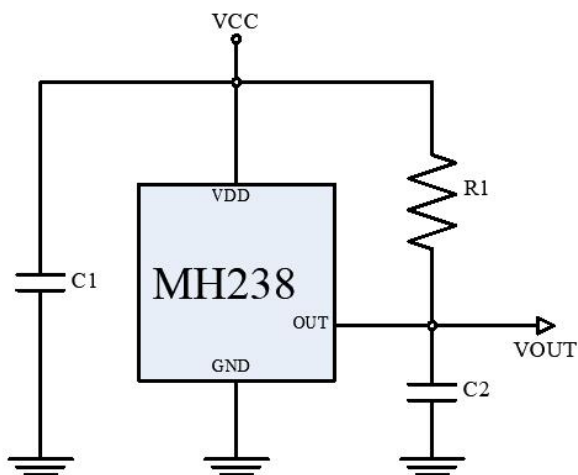

C1: 10nF
 C2: 100pF
 R1: 10K Ω

MH238EUA/SM Magnetic Specifications

DC Operating Parameters: $T_a=25^\circ\text{C}$, $V_{DD}=3.0\text{V}$

Parameter	Symbol	Test Conditions	Min.	Typ.	Max.	Units
Operating Point	B _{OPS}	S pole to branded side, B > BOP, Vout On	20		40	Gauss
	B _{OPN}	N pole to branded side, B > BOP, Vout On	-40		-20	
Release Point	B _{RPS}	S pole to branded side, B < BRP, Vout Off	10		30	Gauss
	B _{RPN}	N pole to branded side, B < BRP, Vout Off	-30		-10	Gauss
Hysteresis	B _{HYS}	BOP _x - BRP _x		10		Gauss

MH238ESO Magnetic Specifications

DC Operating Parameters: $T_a=25^\circ\text{C}$, $V_{DD}=3.0\text{V}$

Parameter	Symbol	Test Conditions	Min.	Typ.	Max.	Units
Operating Point	B _{OPS}	N pole to branded side, B > BOP, Vout On	20		40	Gauss
	B _{OPN}	S pole to branded side, B > BOP, Vout On	-40		-20	Gauss
Release Point	B _{RPS}	N pole to branded side, B < BRP, Vout Off	10		30	Gauss
	B _{RPN}	S pole to branded side, B < BRP, Vout Off	-30		-10	Gauss
Hysteresis	B _{HYS}	BOP _x - BRP _x		10		Gauss

Sensor Location, Package Dimension and Marking

UA Package (TO-92S)

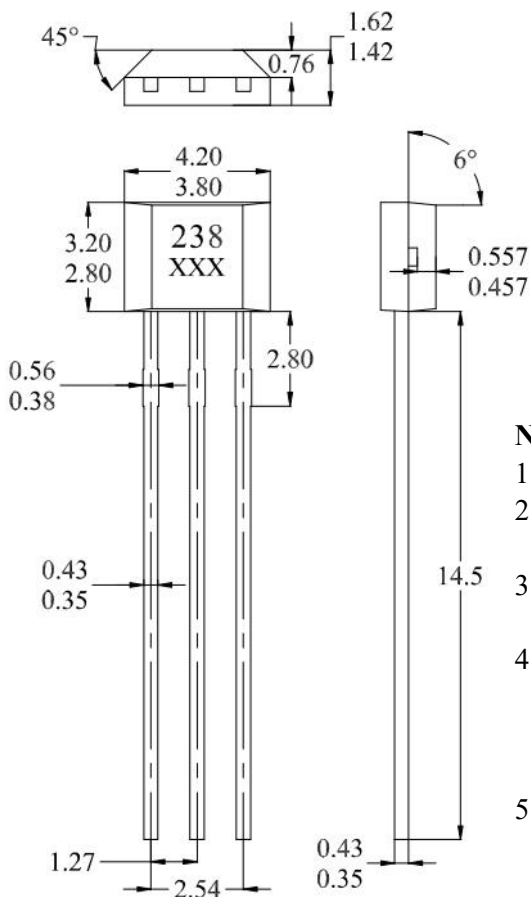

Hall Chip Location

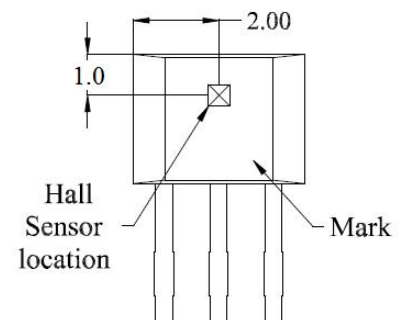

Output Pin Assignment

(Top view)

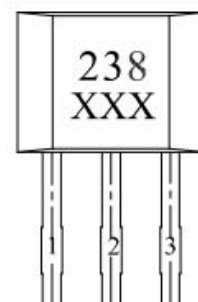

NOTES:

- Controlling dimension: mm
- Leads must be free of flash and plating voids
- Do not bend leads within 1 mm of lead to package interface.
- PINOUT:
Pin 1 VDD
Pin 2 GND
Pin 3 Output
- XXX; 1st X=Year;
2nd and 3rd XX=Week

SO Package (SOT-23)

(Top View)

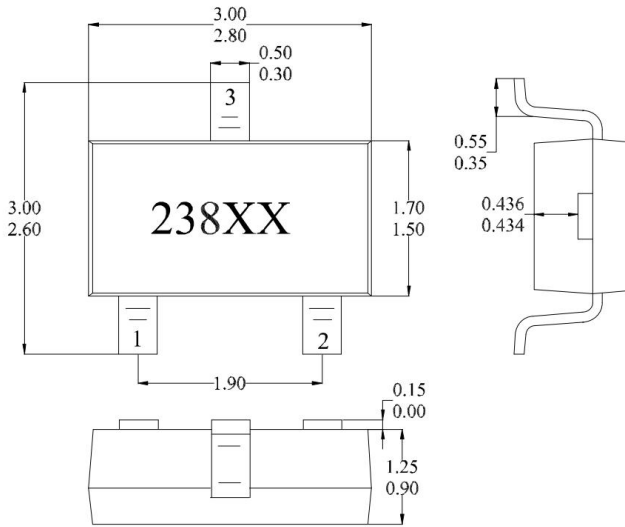

Hall Plate Chip Location

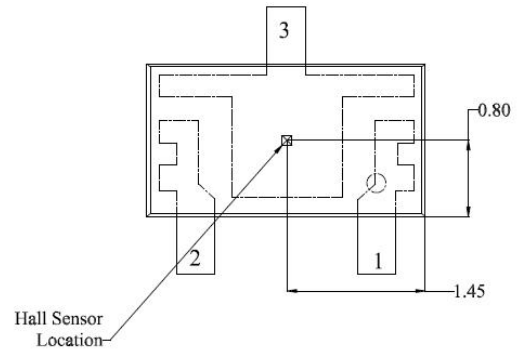

(For reference only) Land Pattern

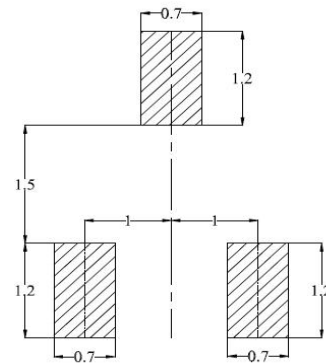

NOTES:

- PINOUT (See Top View at left :)
Pin 1 V_{DD} ; Pin 2 Output; Pin 3 GND
- Controlling dimension: mm
- Lead thickness after solder plating will be 0.254mm maximum
- XX: Date Code, Refer to DC table

SM Package

(Bottom View)

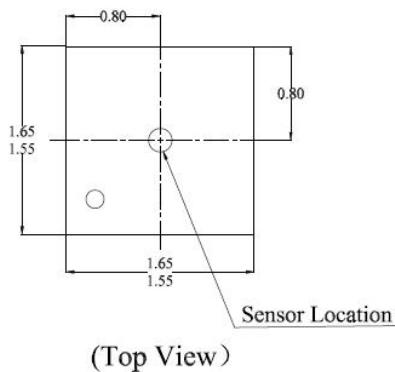
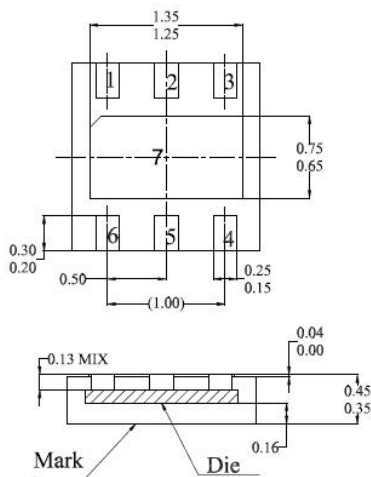

NOTES:

- Controlling dimension: mm
- Leads must be free of flash and plating voids
- Lead thickness after solder plating will be 0.254mm maximum
- PINOUT:

Pin No.	Pin Name	Function
1	V_{DD}	Power Supply
2	N.C	N.C
3	V_{OUT}	Output
4	N.C	N.C
5	V_{SS}	Ground
6	N.C	N.C
7	N.C	N.C

- (For reference only) Land pattern

