



MH254ESN Specifications **Micro-power CMOS Unipolar Hall Effect Switch**

MH254ESN Hall-effect sensor is a temperature stable, stress-resistant, Low Tolerance of sensitivity micro-power switch. Superior high-temperature performance is made possible through a dynamic offset cancellation that utilizes chopper-stabilization. This method reduces the offset voltage normally caused by device over molding, temperature dependencies, and thermal stress.

MH254ESN is special made for low operation voltage, 1.7V, to active the chip which includes the following on a single silicon chip: voltage regulator, Hall voltage generator, small-signal amplifier, chopper stabilization, Schmitt trigger, CMOS output driver. Advanced CMOS wafer fabrication processing is used to take advantage of low-voltage requirements, component matching, very low input-offset errors, and small component geometries. This device requires the presence of unipolar magnetic fields for operation.

The package type is in a Halogen Free version has been verified by third party Lab.

Features and Benefits

- CMOS Hall IC Technology
- Strong RF noise protection
- 1.7 to 5.5V for battery-powered applications
- Operation down to 1.7V, Unipolar Hall Switch Micro power consumption
- High Sensitivity for reed switch replacement applications
- Low sensitivity drift in crossing of Temp. range
- *Ultra Low power consumption at 5uA (Avg)*
- High ESD Protection, HBM > ±4KV(min)
- Totem-pole output
- RoHS compliant 2011/65/EU and Halogen Free

Applications

- Solid state switch
- Handheld Wireless Handset Awake Switch (Flip Cell/PHS Phone/Note Book/Flip Video Set)
- Magnet proximity sensor for reed switch replacement in low duty cycle applications
- Water Meter
- PDA
- PDVD
- NB
- Pad PC

Ordering Information

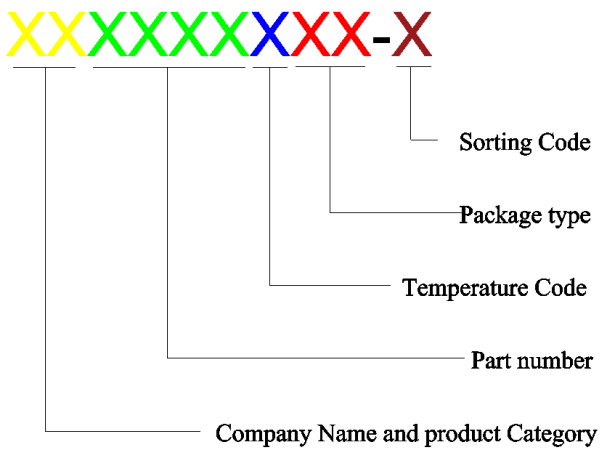
	<p>Company Name and Product Category MH:MST Hall Effect/MP:MST Power IC</p> <p>Part number 181,182,183,184,185,248,249,276,477,381,381E,381R,382..... If part # is just 3 digits, the fourth digit will be omitted.</p> <p>Temperature range E: 85 °C, I: 105 °C, K: 125 °C, L: 150 °C</p> <p>Package type UA:TO-92S,VK:TO-92S(4pin),VF:TO-92S(5pin),SO:SOT-23, SQ:QFN-3,ST:TSOT-23,SN:SOT-553,SF:SOT-89(5pin), SS:TSOT-26,SD:DFN-6</p> <p>Sorting α, β, Blank.....</p>
---	---

Part No.	Temperature Suffix	Package Type
MH254ESN	E (-40°C to + 85°C)	SN (SOT-553)

Custom sensitivity selection is available by MST sorting technology

Functional Diagram

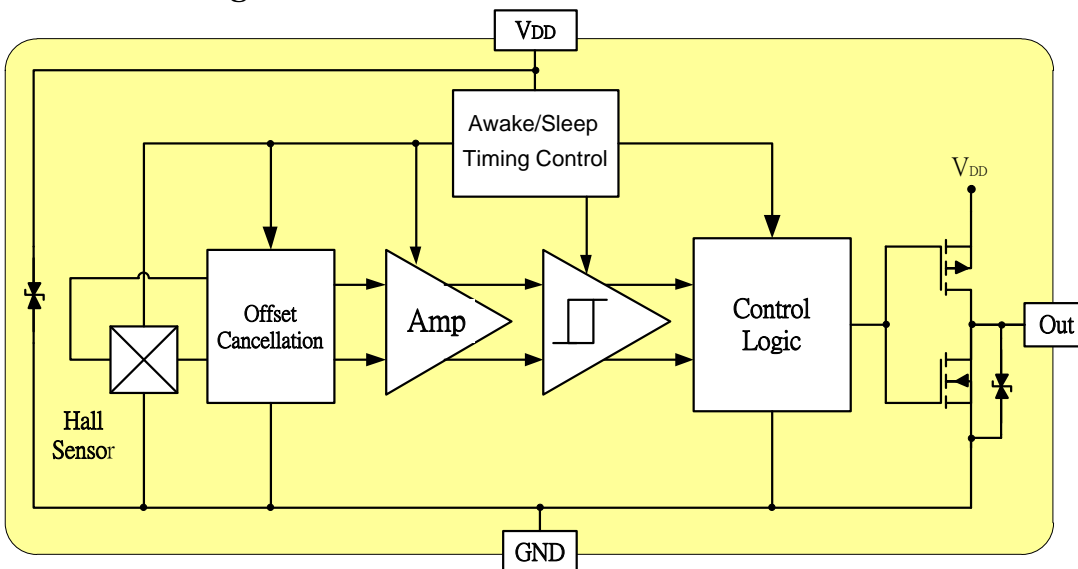

Note: Static sensitive device; please observe ESD precautions. Reverse V_{DD} protection is not included. For reverse voltage protection, a 100 Ω resistor in series with V_{DD} is recommended.

MH254, HBM > $\pm 4KV$ which is verified by third party lab.

Absolute Maximum Ratings At($T_a=25\text{ }^\circ\text{C}$)

Characteristics	Values	Unit	
Supply voltage, (V_{DD})	6	V	
Output Voltage, (V_{out})	6	V	
Reverse Voltage, (V_{DD}) (V_{out})	-0.3	V	
Magnetic flux density	Unlimited	Gauss	
Output current, (I_{out})	5	mA	
Operating temperature range, (T_a)	-40 to +85	$^\circ\text{C}$	
Storage temperature range, (T_s)	-65 to +150	$^\circ\text{C}$	
Maximum Junction Temp, (T_j)	150	$^\circ\text{C}$	
Thermal Resistance	(θ_{JA}) SN	540	$^\circ\text{C/W}$
	(θ_{JC}) SN	390	$^\circ\text{C/W}$
Package Power Dissipation, (P_D) SN	230	mW	

Note: Exceeding the absolute maximum ratings may cause permanent damage. Exposure to absolute maximum-rated conditions for extended periods may affect device reliability.

Electrical Specifications

DC Operating Parameters : $T_a=25\text{ }^\circ\text{C}$, $V_{DD}=1.8\text{V}$

Parameters	Test Conditions	Min	Typ	Max	Units
Supply Voltage, (V_{DD})	Operating	1.7		5.5	Volts
Supply Current, (I_{DD})	Awake State		1.5	3	mA
	Sleep State		3.5	7	μA
	Average		5	10	μA
Output Leakage	Output off			1	μA
Output High Voltage, (V_{OH})	$I_{OUT}=0.5\text{mA}$ (Source)	$V_{DD}-0.2$			V
Output Low Voltage, (V_{OL})	$I_{OUT}=0.5\text{mA}$ (Sink)			0.2	V
Awake mode time, (T_{aw})	Operating		40	80	μs
Sleep mode time, (T_{sl})	Operating		40	80	mS
Duty Cycle, (D,C)			0.1		%
Electro-Static Discharge	HBM	4			KV

MH254ESN Magnetic Specifications

DC Operating Parameters : $T_a=25\text{ }^\circ\text{C}$, $V_{DD}=1.8\text{V}$

Parameter	Symbol	Test Conditions	Min.	Typ.	Max.	Units
Operating Point	B_{OP}	S pole to branded side, $B > B_{OP}$, V_{out} On		30	50	Gauss
Release Point	B_{RP}	S pole to branded side, $B < B_{RP}$, V_{out} Off	10	20		Gauss
Hysteresis	B_{HY}	$ B_{OPx} - B_{RPx} $		10		Gauss

Typical application circuit

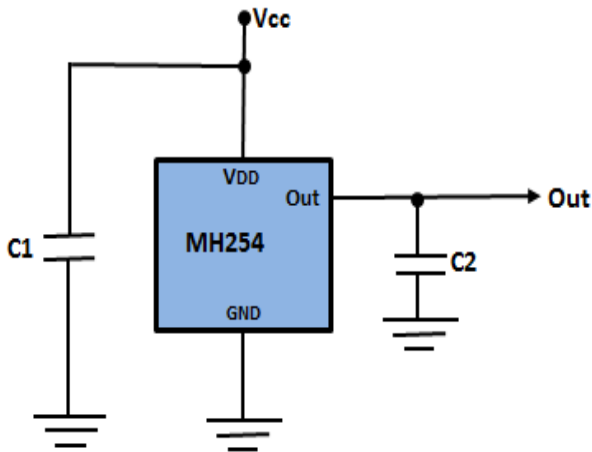

C1 : 10nF
 C2 : 100pF

Sensor Location, package dimension and marking

SN Package (SOT-553)

(Top View)

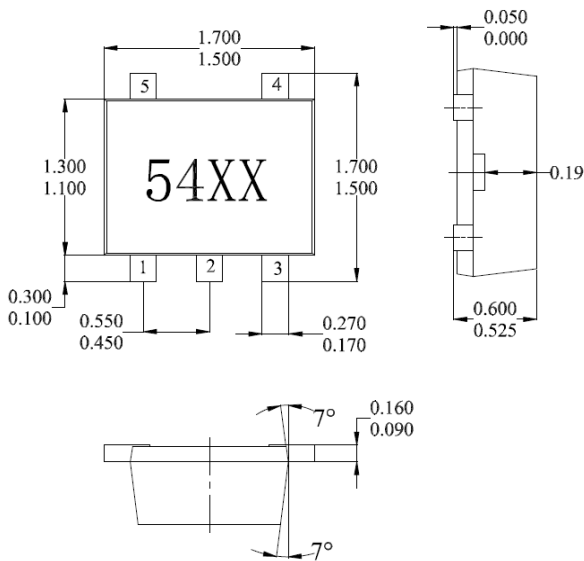

Hall Plate Chip Location

(Top View)

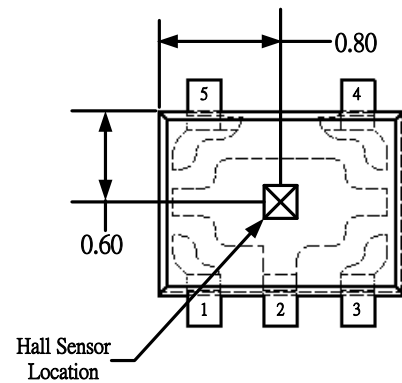

(For reference only) Land Pattern

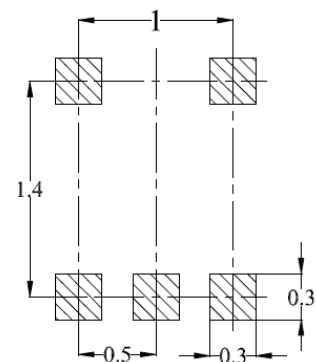

NOTES:

1. PINOUT (See Top View at left:):
 - Pin 1 NC
 - Pin 2 GND
 - Pin 3 NC
 - Pin 4 VDD
 - Pin 5 Out
2. Controlling dimension: mm;