

MH50XX is a low-voltage, low-power linear Hall effect IC that operates from a 1.7V to 5.5V supply. The output signal level depends on the magnetic field strength applied to the chip surface and varies proportionally with the magnetic field strength. When the chip is in a zero magnetic field environment, its output voltage is half of the supply voltage. Its sensitivity varies proportionally with the supply voltage. At the same time, MH50XX has the advantages of low output noise and good temperature stability.

MH50XX is rated for operation between the ambient temperatures -40°C and $+125^{\circ}\text{C}$ for the K temperature range. The three package styles available provide magnetically optimized solutions for most applications. Package types SM is a DFN1616-6L(0.4 mm nominal height), SO is an SOT-23(1.1 mm nominal height), a miniature low-profile surface-mount package, while package UA is a three-lead ultra-mini SIP for through-hole mounting.

All of them are ROHS compliant 2011/65/EU and Halogen Free

Features and Benefits

- Operating voltage range: 1.7~5.5 V
- Operating temperature range: $-40\sim 125^{\circ}\text{C}$
- Low power consumption current: $I_{cc}=850\mu\text{A}$ @ $V_{cc}=1.8\text{V}$
- Fast responding time: 40us (TYP)
- Low output noise, good stability
- ROHS compliant 2011/65/EU and Halogen Free

Applications

- Game pad Joystick
- Proximity detection
- Headphone position detection
- Magnetic Keyboard
- Precious position detection
- Accelerator

Absolute Maximum Ratings At($T_a=25^{\circ}\text{C}$)

Characteristics	Values	Unit
Supply Voltage, (V_{CC})	6	V
Reverse Voltage, (V_{CC})	-0.1	V
Magnetic Flux Density	Unlimited	Gauss
Output Voltage, (V_{out})	6	V
Operating Temperature Range, (T_a)	-40 to +125	$^{\circ}\text{C}$
Storage temperature range, (T_s)	-65 to +165	$^{\circ}\text{C}$
Maximum Junction Temp, (T_j)	165	$^{\circ}\text{C}$
Package Power Dissipation, (PD)UA/SO/SM	603/230/500	mW

Note: Do not apply reverse voltage to V_{CC} and V_{OUT} Pin, it may be caused by Miss function or damaged device.

Electrical Specifications

DC Operating Parameters: $T_A=+25^{\circ}\text{C}$, $V_{CC}=5.0\text{V}$

Parameters		Test Conditions	Min	Typ	Max	Units
Supply Voltage, (V_{CC})		Operating	1.7	3.3	5.5	V
Supply Current, (I_{CC})		B=0Gauss		1.3	1.5	mA
Bandwidth, (B_w)	SO/UA	$T_A=25^{\circ}\text{C}$		9.6		kHz
	SM			4.8		kHz
Output impedance, (R_{OUT})		OUT to GND		5	10	Ω
output load capacitance, (C_L)		$T_A=25^{\circ}\text{C}$		1		nF
Power-up time, (T_R)		$T_A=25^{\circ}\text{C}$, $C_L=1\text{nF}$			50	us
Response time, (T_{RESP})		$T_A=25^{\circ}\text{C}$		40		us
Linear output low voltage, (V_{OL})		$T_A=25^{\circ}\text{C}$			0.1	V
Linear output high voltage, (V_{OH})		$T_A=25^{\circ}\text{C}$	$V_{CC}-0.1$			V
Linearity Error, (E_{LIN})		$T_A=25^{\circ}\text{C}$	-1.5		1.5	%
Zero magnetic field output voltage, (V_{OQ})		B=0Gauss		$0.5*V_{CC}$		V
Zero magnetic field output voltage temperature drift, (V_{OQ_TC})			-2		2	%
Zero magnetic field output voltage error, (V_{OE})		$T_A=25^{\circ}\text{C}$		$0.1*V_{CC}$		V
Sensitivity $V_{CC}=5.0\text{V}$	SO/UA/SM	MH5001		1.0		mV/G
		MH501P		1.5		mV/G
		MH5002		2.0		mV/G
		MH5003		3.0		mV/G
		MH5004		4.0		mV/G
		MH5007		7.0		mV/G
		MH5013		13.0		mV/G
Sensitivity $V_{CC}=3.3\text{V}$	SO/UA/SM	MH5001		0.6		mV/G
		MH501P		1.0		mV/G
		MH5002		1.3		mV/G
		MH5003		2.0		mV/G
		MH5004		2.6		mV/G

	MH5007		4.6		mV/G
	MH5013		8.6		mV/G
Magnetic Range Gauss VCC=5.0V	MH5001		±2400		Gauss
	MH501P		±1600		Gauss
	MH5002		±1200		Gauss
	MH5003		±800		Gauss
	MH5004		±600		Gauss
	MH5007		±340		Gauss
	MH5013		±180		Gauss
Magnetic Range Gauss VCC=3.3V	MH5001		±2200		Gauss
	MH501P		±1550		Gauss
	MH5002		±1190		Gauss
	MH5003		±770		Gauss
	MH5004		±590		Gauss
	MH5007		±330		Gauss
	MH5013		±180		Gauss
Sensitivity temperature drift, (<i>SNS_TC</i>)			1000		PPM/°C
Output noise, (<i>V_N</i>)	VCC=4.0V, T _A =25°C, BW=9.6kHz		14		mVpp
Electro-Static Discharge	HBM			4	kV

Typical application circuit

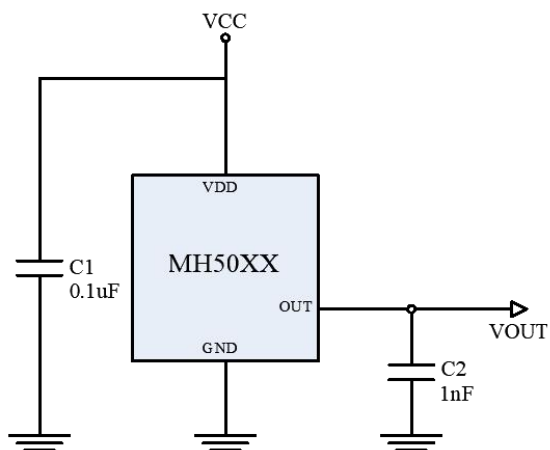

Sensor Location, package dimension and marking

UA Package (TO-92S)

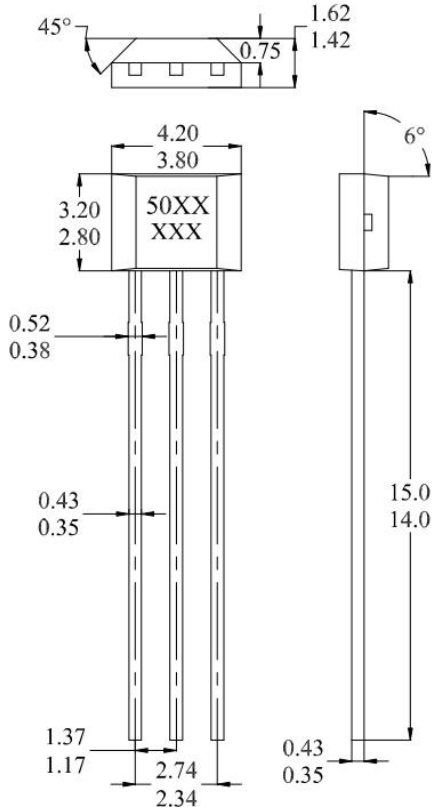

Hall Chip location

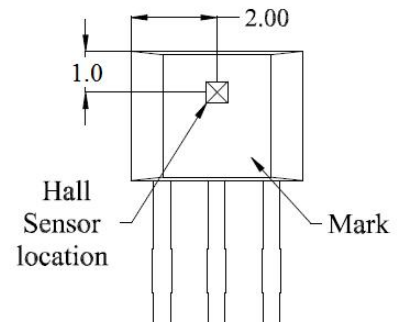

Output Pin Assignment (Top view)

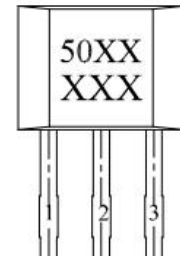

NOTES:

1. Controlling dimension: mm
2. Leads must be free of flash and plating voids
3. Do not bend leads within 1 mm of lead to package interface
4. PINOUT:
Pin 1 VCC
Pin 2 GND
Pin 3 Output
5. The XX in the 1st line represents Sens. In the 2nd line, XXX=Date Code (Refer to DC table)

SO Package (SOT23-3L) (Top View)

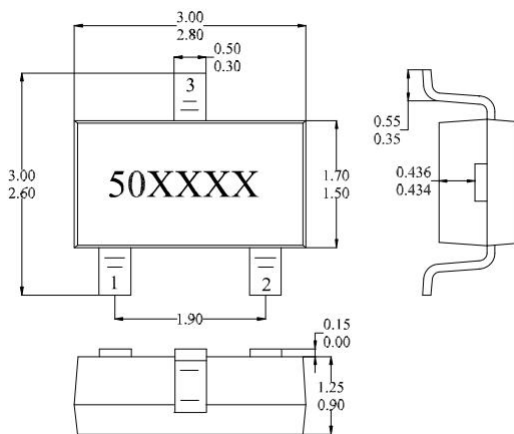

Hall Plate Chip Location (Bottom view)

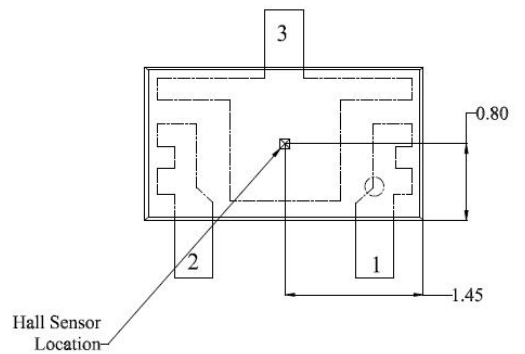

(For reference only) Land Pattern

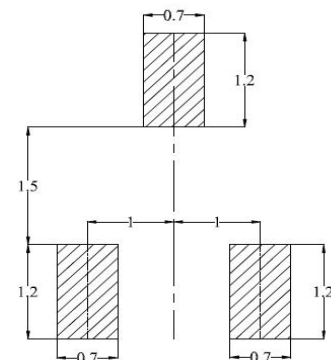

NOTES:

1. PINOUT (See Top View at left :)
Pin 1 V_{DD}; Pin 2 Output; Pin 3 GND
2. Controlling dimension: mm
3. Lead thickness after solder plating will be 0.254mm maximum
4. Chip must be in PKG. center.
5. Marking info: The first two X=Sens; The last two X=Date code (Refer to DC table)

SM Package

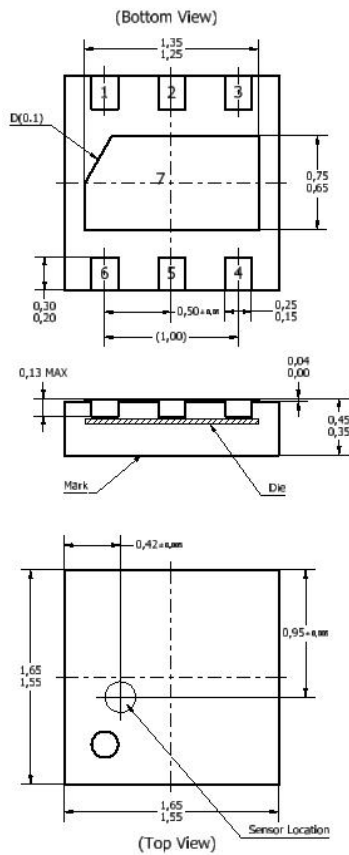

NOTES:

1. Controlling dimension: mm
2. Leads must be free of flash and plating voids
3. Lead thickness after solder plating will be 0.254mm maximum.
4. PINOUT:

Pin	Pin Name	Function
1	VCC	Power
2	NC	
3	Out	Output/Programming
4	NC	
5	GND	Ground
6	NC	

5. Marking info: The 1st line XX =Sens; The 2nd line XX=Date code
(Refer to DC table)

(For reference only) Land Pattern

