

MH231 Hall-effect sensor is a temperature stable, stress-resistant, Low Tolerance of Sensitivity nano-power switch. Superior high-temperature performance is made possible through a dynamic offset cancellation that utilizes chopper-stabilization. This method reduces the offset voltage normally caused by device over molding, temperature dependencies, and thermal stress.

MH231 is special made for low operation voltage, 1.65V, to active the chip which includes the following on a single silicon chip: voltage regulator, Hall voltage generator, small-signal amplifier, chopper stabilization, Schmitt trigger, CMOS output driver. Advanced CMOS wafer fabrication processing is used to take advantage of low-voltage requirements, component matching, very low input-offset errors, and small component geometries. This device requires the presence of omni-polar magnetic fields for operation.

The package type is in a Halogen Free version has been verified by third party Lab.

Features and Benefits

- CMOS Hall IC Technology
- Strong RF noise protection
- 1.65 to 5.5V for battery-powered applications
- Omni polar, output switches with absolute value of North or South pole from magnet
- Operation down to 1.65V, Nano power consumption
- High Sensitivity for reed switch replacement applications
- Multi Small Size option
- Low sensitivity drift in crossing of Temp. range
- Ultra Low power consumption at 900nA (Avg)
- High ESD Protection, HBM $> \pm 8\text{KV}$ (min)
- Totem-pole output
- RoHS compliant 2011/65/EU and Halogen Free.

Applications

- Solid state switch
- Handheld Wireless Handset Awake Switch (Flip Cell/PHS Phone/Note Book/Flip Video Set)
- Lid close sensor for battery powered devices
- Magnet proximity sensor for reed switch replacement in low duty cycle applications
- Water Meter
- Floating Meter
- PDVD
- NB

Ordering Information

	<p>Company Name and Product Category</p> <p>MH:MST Hall Effect/MP:MST Power IC</p> <p>Part number</p> <p>181,182,183,184,185,248,249,276,477,381,381F,381R,382.....</p> <p>If part # is just 3 digits, the fourth digit will be omitted.</p> <p>Temperature range</p> <p>E: 85 °C, I: 105 °C, K: 125 °C, L: 150 °C</p> <p>Package type</p> <p>UA:TO-92S,VK:TO-92S(4pin),VF:TO-92S(5pin),SO:SOT-23, SQ:QFN-3,ST:TSOT-23,SN:SOT-553,SF:SOT-89(5pin), SS:TSOT-26,SD:DFN-6; SA:Represents ATEC packaged TSOT-23.</p> <p>Sorting</p> <p>α,β,Blank.....</p>
<p>Sorting Code</p> <p>Package type</p> <p>Temperature Code</p> <p>Part number</p> <p>Company Name and product Category</p>	

Part No.	Temperature Suffix	Package Type
MH231EUA	E (-40°C to + 85°C)	UA (TO-92S)
MH231ESO	E (-40°C to + 85°C)	SO (SOT-23)
MH231ESO-AA	E (-40°C to + 85°C)	SO (SOT-23)
MH231ESA	E (-40°C to + 85°C)	SA (SOT-23)
MH231ESP	E (-40°C to + 85°C)	SP (PSOT-23)
MH231ESS	E (-40°C to + 85°C)	SS (DFN1x1-4L)
MH231ESM	E (-40°C to + 85°C)	SM (DFN1.6*1.6-6L)

Functional Diagram

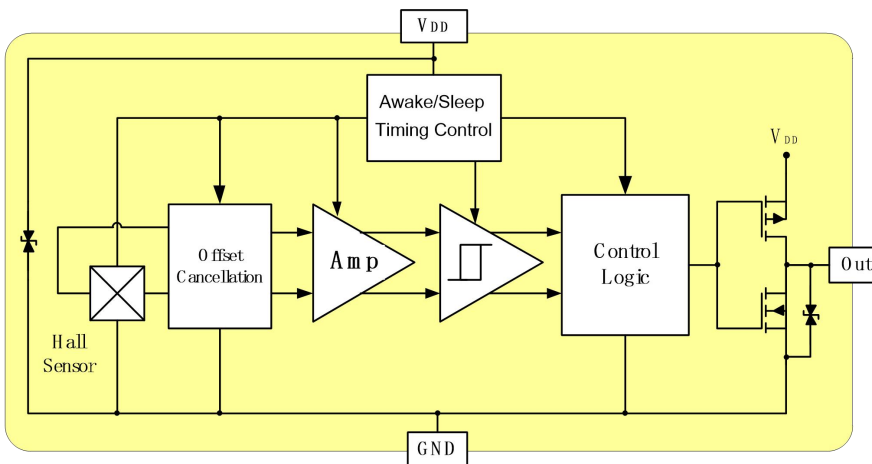

Note: Static sensitive device; please observe ESD precautions. Reverse V_{DD} protection is not included. For reverse voltage protection, a 100 Ω resistor in series with V_{DD} is recommended.
MH231, HBM $\geq \pm 8KV$ which is verified by third party lab.

Absolute Maximum Ratings At($T_a=25^{\circ}\text{C}$)

Characteristics	Values	Unit
Supply voltage, (V_{DD})	6	V
Output Voltage, (V_{out})	6	V
Reverse Voltage, (V_{DD}) (V_{out})	-0.3	V
Magnetic flux density	Unlimited	Gauss
Output current, (I_{out})	10	mA
Operating temperature range, (T_a)	-40 to +85	$^{\circ}\text{C}$
Storage temperature range, (T_s)	-65 to +150	$^{\circ}\text{C}$
Maximum Junction Temp, (T_j)	150	$^{\circ}\text{C}$

Note: Exceeding the absolute maximum ratings may cause permanent damage. Exposure to absolute maximum-rated conditions for extended periods may affect device reliability.

Electrical Specifications

DC Operating Parameters: $T_a=25^{\circ}\text{C}$, $V_{DD}=3.0\text{V}$

Parameters	Test Conditions	Min	Typ	Max	Units
Supply Voltage, (V_{DD})	Operating	1.65		5.5	V
Supply Current, (I_{DD})	Average		900		nA
Output Leakage Current, (I_{off})	Output off			1	μA
Output High Voltage, (V_{OH})	$I_{OUT}=0.5\text{mA}$ (Source)	$V_{DD}-0.04$			mV
Output Low Voltage, (V_{OL})	$I_{OUT}=0.5\text{mA}$ (Sink)			0.04	mV
Awake mode time, (T_{aw})	Operating		25	50	μs
Sleep mode time, (T_{SL})	Operating		35	50	mS
Sampling period			35		mS
Electro-Static Discharge	HBM	8			KV

Typical Application Circuit

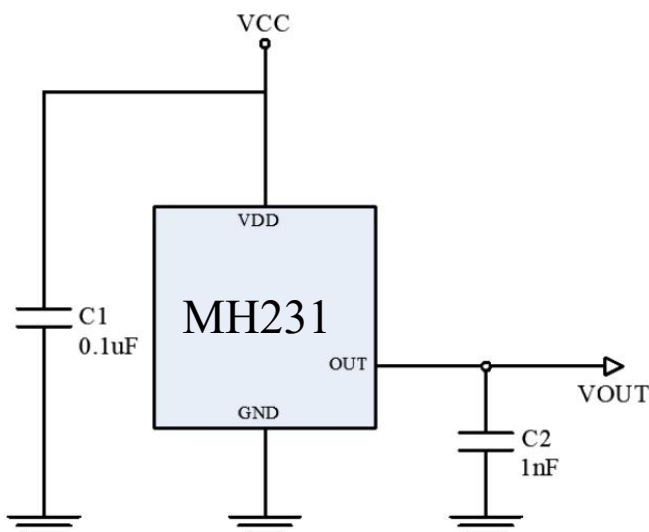

MH231EUA/SP/SS/SM Magnetic Specifications

DC Operating Parameters: $T_a=25\text{ }^\circ\text{C}$, $V_{DD}=3.0\text{V}$

Parameter	Symbol	Test Conditions	Min.	Typ.	Max.	Units
Operating Point	B _{OPS}	S pole to branded side, $B > \text{BOP}$, Vout On	20		40	Gauss
	B _{OPN}	N pole to branded side, $B > \text{BOP}$, Vout On	-40		-20	Gauss
Release Point	B _{RPS}	S pole to branded side, $B < \text{BRP}$, Vout Off	10		30	Gauss
	B _{RPN}	N pole to branded side, $B < \text{BRP}$, Vout Off	-30		-10	Gauss
Hysteresis	B _{HYS}	$ \text{BOP}_x - \text{BRP}_x $		10		Gauss

MH231ESO/SA Magnetic Specifications

DC Operating Parameters: $T_a=25\text{ }^\circ\text{C}$, $V_{DD}=3.0\text{V}$

Parameter	Symbol	Test Conditions	Min.	Typ.	Max.	Units
Operating Point	B _{OPS}	N pole to branded side, $B > \text{BOP}$, Vout On	20		40	Gauss
	B _{OPN}	S pole to branded side, $B > \text{BOP}$, Vout On	-40		-20	Gauss
Release Point	B _{RPS}	N pole to branded side, $B < \text{BRP}$, Vout Off	10		30	Gauss
	B _{RPN}	S pole to branded side, $B < \text{BRP}$, Vout Off	-30		-10	Gauss
Hysteresis	B _{HYS}	$ \text{BOP}_x - \text{BRP}_x $		10		Gauss

MH231ESO-AA Magnetic Specifications

DC Operating Parameters: $T_a=25\text{ }^\circ\text{C}$, $V_{DD}=3.0\text{V}$

Parameter	Symbol	Test Conditions	Min.	Typ.	Max.	Units
Operating Point	B _{OPS}	N pole to branded side, $B > \text{BOP}$, Vout On	25		35	Gauss
	B _{OPN}	S pole to branded side, $B > \text{BOP}$, Vout On	-35		-25	Gauss
Release Point	B _{RPS}	N pole to branded side, $B < \text{BRP}$, Vout Off	15		28	Gauss
	B _{RPN}	S pole to branded side, $B < \text{BRP}$, Vout Off	-28		-15	Gauss
Hysteresis	B _{HYS}	$ \text{BOP}_x - \text{BRP}_x $		10		Gauss

MH231EUA/SO/SA/SP/SS/SM/MH231ESO-AA Output Behavior versus Magnetic Polarity

DC Operating Parameters : $T_a = -40\text{ to }85\text{ }^\circ\text{C}$, $V_{DD}=1.65\text{V to }5.5\text{V}$

Parameter	Test condition	OUT(SO/SA)	Test condition	OUT(UA/SP/SS/SM)
South pole	$B < \text{BOPN}$	Low	$B > \text{BOPS}$	Low
Null or weak magnetic field	$B=0$ or $B < \text{BRP} $	High	$B=0$ or $B < \text{BRP} $	High
North pole	$B > \text{BOPS}$	Low	$B < \text{BOPN}$	Low

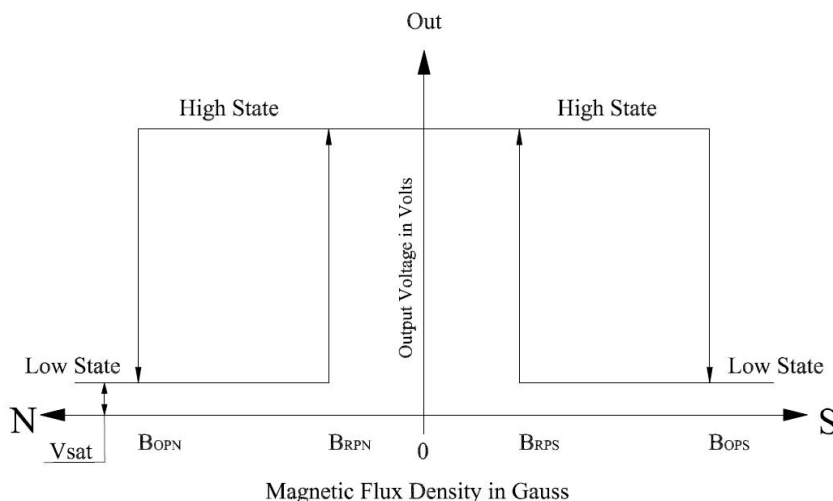

Sensor Location, Package Dimension and Marking

UA Package (TO-92S)

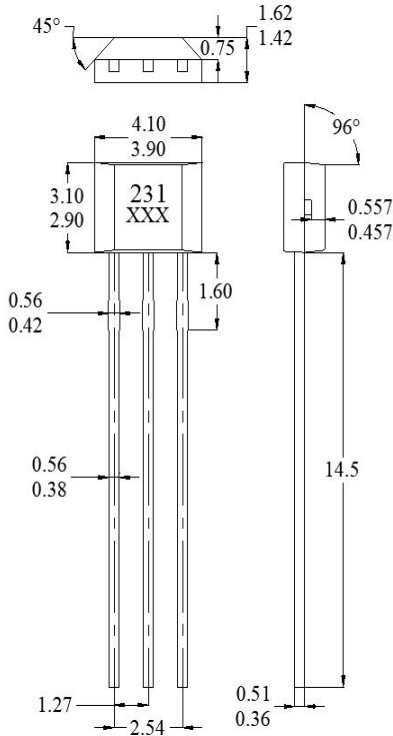

Hall Chip Location

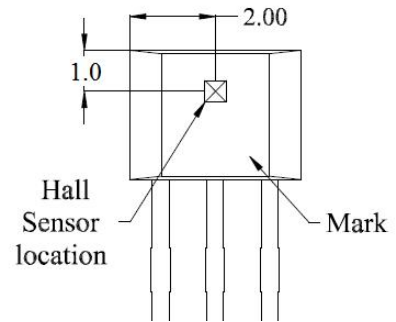

**Output Pin Assignment
(Top view)**

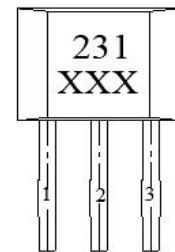

NOTES:

1. Controlling dimension: mm
 2. Leads must be free of flash and plating voids
 3. Do not bend leads within 1 mm of lead to package interface.
 4. PINOUT:
- | | |
|-------|--------|
| Pin 1 | VCC |
| Pin 2 | GND |
| Pin 3 | Output |

SO Package (SOT-23)

(Top View)

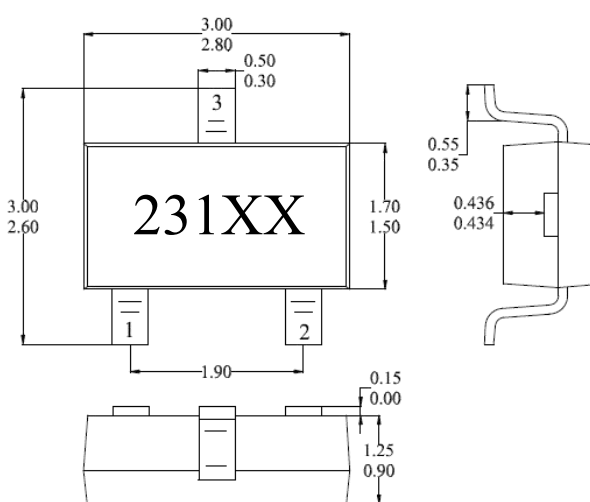

Hall Plate Chip Location

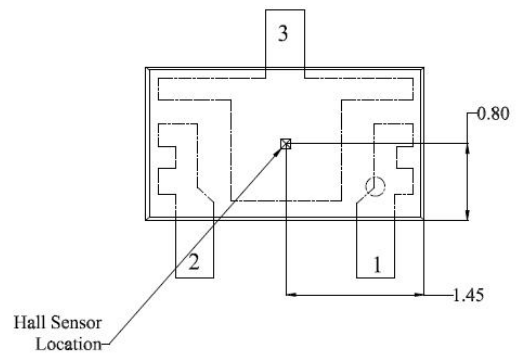

(For reference only) Land Pattern

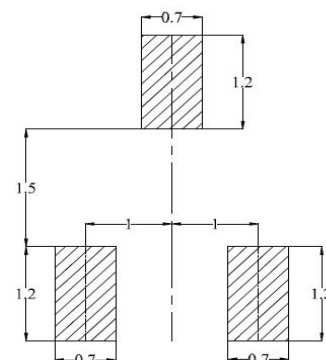

NOTES:

- 1 PINOUT (See Top View at left :)
 Pin 1 V_{DD}; Pin 2 Output; Pin 3 GND
- 2 Controlling dimension: mm
- 3 Lead thickness after solder plating will be 0.254mm maximum
- 4 XX: Date Code, Refer to DC table

SA Package (SOT-23)

(Top View)

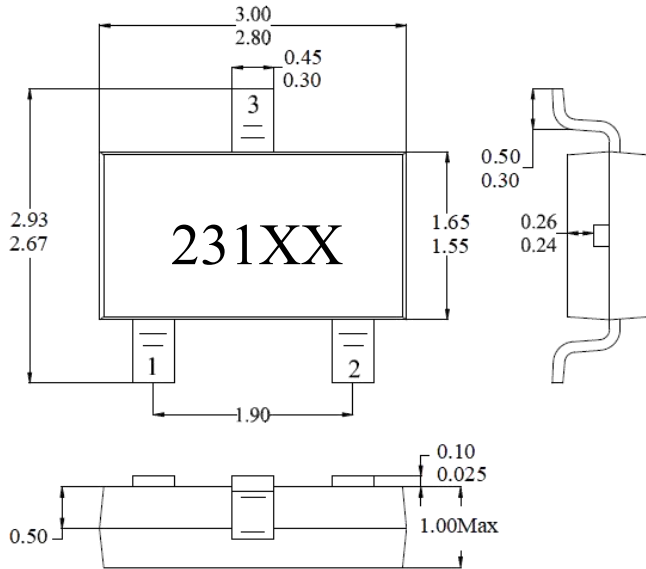

NOTES:

- PINOUT (See Top View at left :)
Pin 1 V_{DD}; Pin 2 Output; Pin 3 GND
- Controlling dimension: mm
- Lead thickness after solder plating will be 0.254mm maximum
- XX: Date Code, Refer to DC table

Hall Plate Chip Location

(Bottom view)

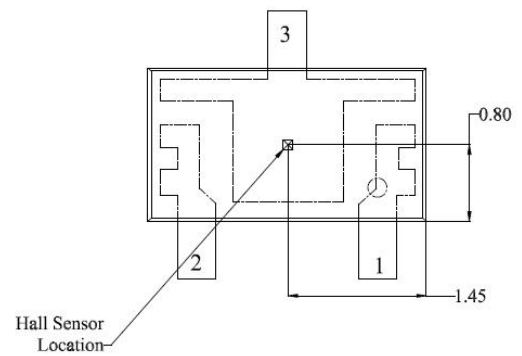

(For reference only) Land Pattern

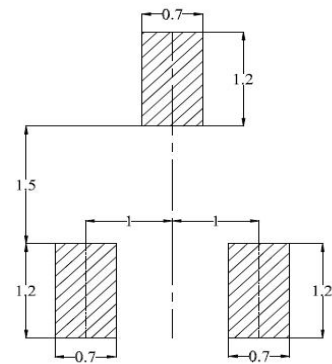

SP Package (PSOT-23)

(Top View)

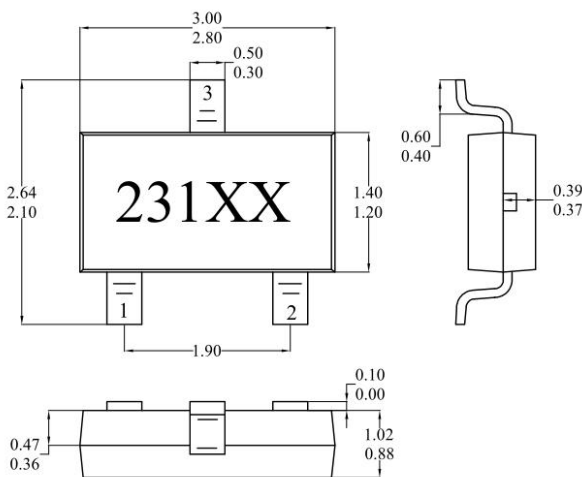

NOTES:

- PINOUT (See Top View at left :)
Pin 1 V_{DD}
Pin 2 Output
Pin 3 GND
- Controlling dimension: mm
- Lead thickness after solder plating will be 0.254mm maximum

Hall Plate Chip Location

(Bottom view)

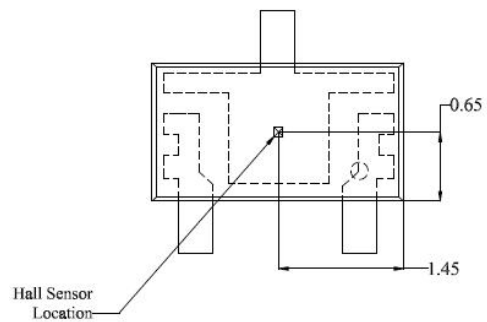

(For reference only) Land Pattern

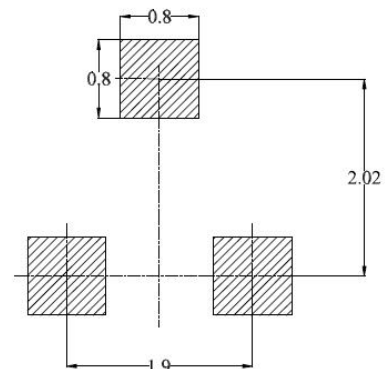

SS Package (DFN1x1-4L)

(Top View)

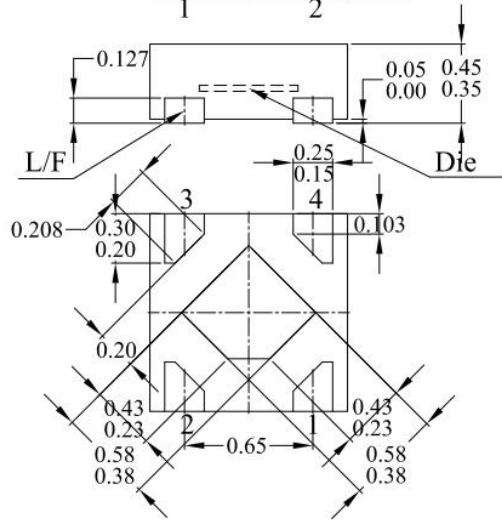
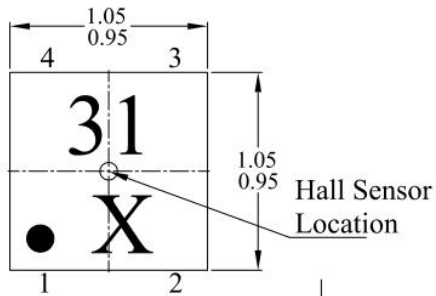

(Bottom View)

NOTES:

Controlling dimension: mm

1. Leads must be free of flash and plating voids
2. Lead thickness after solder plating will be 0.254mm maximum
3. X: Date Code, Refer to DC table
4. PINOUT:

Pin No.	Pin Name	Function
1	VCC	Power Supply
2	GND	Ground
3	NC	-
4	OUT	Output

(For reference only) Land pattern

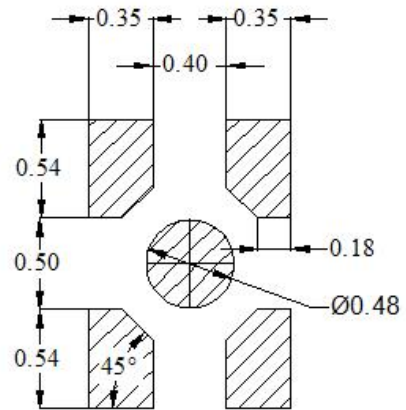

SM Package(DFN1.6*1.6-6L) (Bottom View)

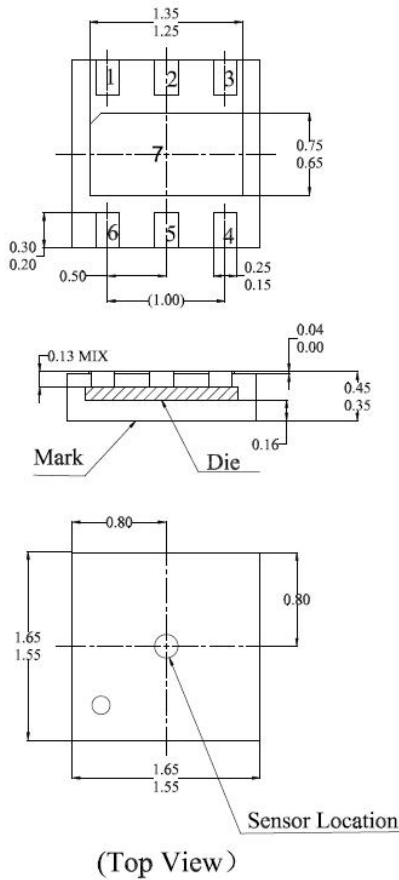

NOTES:

1. Controlling dimension: mm
2. Leads must be free of flash and plating voids
3. Lead thickness after solder plating will be 0.254mm maximum
4. PINOUT:

Pin No.	Pin Name	Function
1	V _{DD}	Power Supply
2	N.C	N.C
3	V _{OUT}	Output
4	N.C	N.C
5	V _{SS}	Ground
6	N.C	N.C
7	N.C	N.C

(For reference only) Land pattern

